

## SERVISNÍ MANUÁL PEGAS 200 AC-DC PULSE

## SERVICE MANUAL PEGAS 200 AC-DC PULSE



### 1. VAROVÁNÍ

### WARNING

**UPOZORNĚNÍ – Pouze osoba splňující kvalifikaci danou zákonem je oprávněna opravovat stroj.**

**NOTE Only trained personnel are permitted to work inside the machine.**

**PŘED OTEVŘENÍM KRYTU STROJE JEJ ODPOJTE VYTAŽENÍM SÍTOVÉ VIDLICE ZE SÍTĚ.**

**BEFORE OPENING THE MACHINE, CUT OFF ITS ELECTRICAL POWER BY REMOVING THE PLUG FROM THE MAINS SUPPLY SOCKET.**

**Každé 4 měsíce otevřete stroj a jemně ho vyfoukejte stlačeným suchým vzduchem POZOR, NEPOUŽÍVEJTE STLAČENÝ VZDUCH O PŘÍLIŠ VYSOKÉM TLAKU, ABY NEDOŠLO K MECHANICKÉMU POŠKOZENÍ ELEKTROSOUČÁSTEK.**

**Every six months, open the machine and clean it inside, using compressed dehumidified air. CAUTION. DO NOT USE COMPRESSED AIR AT TOO HIGH A PRESSURE. YOU COULD DAMAGE THE ELECTRONIC COMPONENTS.**

**Každé 4 měsíce zkontrolujte řádný stav svařovacích kabelů a síťových kabelů.**

**With the same frequency, check the welding cables and the supply cables.**

**Není povolena žádná modifikace svařovacího stroje.**

**No modification, of any type, may be made to the welding machine.**

**Pro Vaši bezpečnost je nutné posečkat se sundáním krytu ze stroje po odpojení ze sítě po dobu minimálně 5 minut, kdy klesne napětí na kondenzátorech na hodnotu pod 36 V.**

**For safety while maintaining the machine, please shut off the supply power and wait for 5 minutes, until capacity voltage already drops to safe voltage 36V.**

### 2. BLOKOVÉ SCHÉMA

### ELECTRICAL PRINCIPLE DRAWING

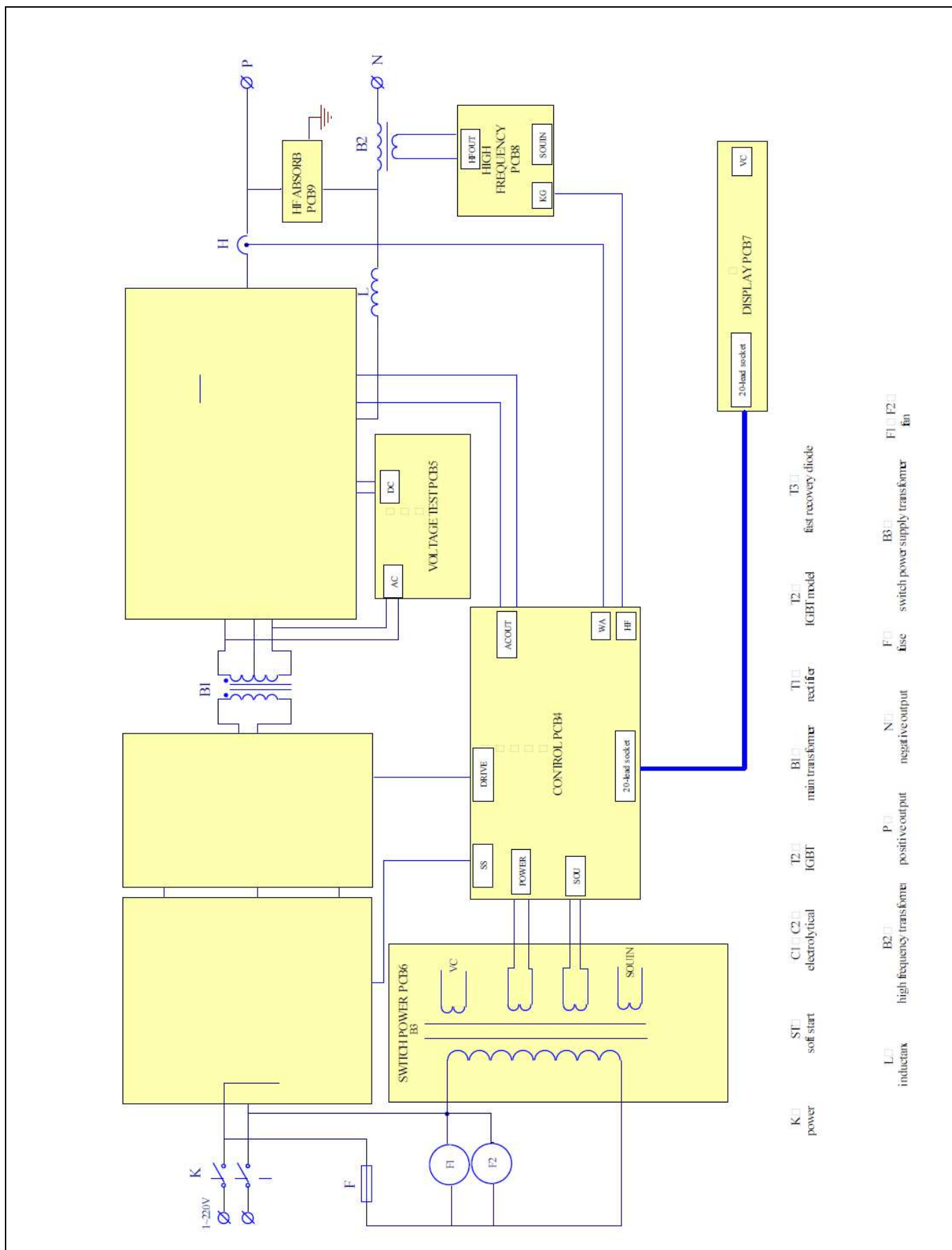

- K  power
- ST  soft start
- L  inductor
- B1  main transformer
- B2  high frequency transformer
- B3  switch power supply transformer
- T1  rectifier
- T2  IGBT
- T3  first recovery diode
- C1  C2  electrolytical
- P  positive output
- N  negative output
- F1  fuse
- F2  fan
- VC  20-lead socket
- DC  DC
- AC  AC
- DRIVE  DRIVE
- ACOUT  ACOUT
- WA  WA
- HF  HF
- SOUTIN  SOUTIN
- POWER  POWER
- SS  SS
- HFOUT  HFOUT
- SOUIN  SOUIN
- VC  VC
- 20-lead socket  20-lead socket
- DISPLAY PCB7  DISPLAY PCB7
- VOLTAGE TEST PCB5  VOLTAGE TEST PCB5
- HIGH FREQUENCY PCB8  HIGH FREQUENCY PCB8
- HF ABSORB PCB9  HF ABSORB PCB9

## 3. NÁHRADNÍ DÍLY

## SPARE PARTS

WSME-160 3.006.517-E  
WSME-200 3.006.518-E

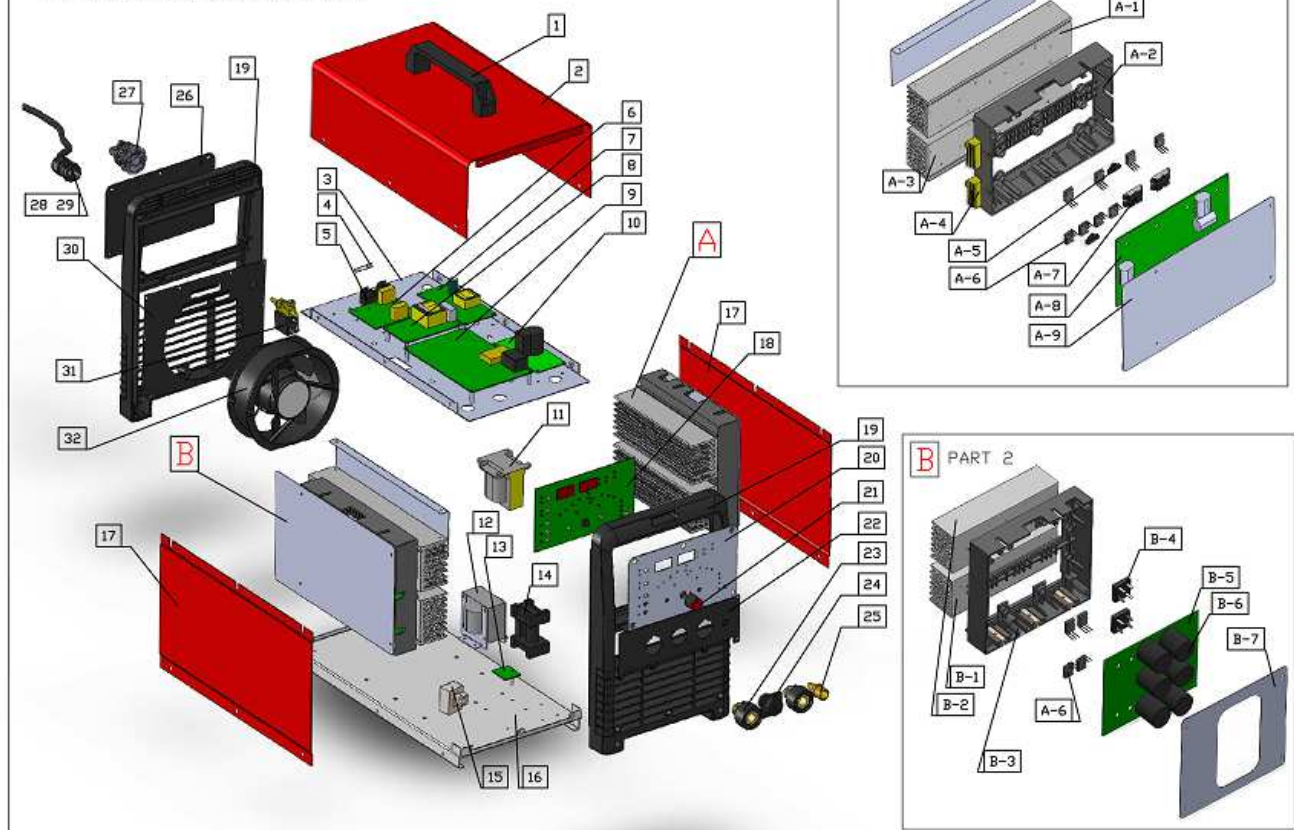

Pos	Item No	Popis	Description	Quantity
1	8.253.020	Držák - madlo P250	Handle P250	1
2	8.301.099	Kryt horní P250	Upper Cover P250	1
3	8.062.543	PCB Installation Panel P200AC-DC	PCB Installation Panel P200AC-DC	1
4	7.202.123	Pojistka 3A	Fuse 3A	1
5	7.202.029	Držák pojistek P200AC-DC	Fuse Holder P200AC-DC	1
6	5.496.931	PCB EMC P200AC-DC	PCB EMC P200AC-DC	1
7	5.496.526-B	Spínaný zdroj PCB P200AC-DC	SWITCH POWER PCB P200AC-DC	1
8	5.496.875-E	PCB měření napětí	Voltage test PCB P200AC-DC	1
9	5.496.415-E	PCB řídicí P200P AC-DC	Control PCB P200P AC-DC	1
10	5.496.373-C	PCB HF P200AC-DC	PCB HF P200AC-DC	1
11	6.185.515	Hlavní transformátor P200AC-DC	Main transformer P200AC-DC	1
12	6.271.515	Tlumivka P200AC-DC	Choke P200AC-DC	1







13	5.496.204-B	HF filtr PCB P200P AC-DC	HF filter PCB P200P AC-DC	1
14	6.174.515	Trafo HF P200AC-DC	Transformer HF P200AC-DC	1
15	7.321.002	Sonda Hall 200A Pegas	Hall sensor 200A Pegas	1
16	8.055.543	Kryt spodní P200AC-DC	Bottom Plate P200AC-DC	1
17	8.050.099	Kryt boční P250	Side Cover P250	2
18	5.496.416-B	PCB přední P200P AC-DC	Front PCB P200P AC-DC	1
19	8.068.099	Panel přední/zadní plast P250	Plastic Front/Rear Panel P250	1
20	8.306.441	Panel přední kov P200P AC-DC+fólie	Metal Front Panel P200P AC-DC+folie	1
21	7.458.053	Knoflík Pegas černý P200P	Knob Pegas black P200P	1
22	8.065.570	Panel přední kov spodní P200AC-DC	Metal Front Panel For Output P200AC-DC	1
23	7.152.312	Rychlosp. 35-70mm P250	35-70mm Socket P250	2
24	7.132.114	Konektor zásuvka P250	14-Pin Socket P250	1
25	8.462.104	Konektor plyn Pegas P200AC-DC	Gas Connector Pegas P200AC-DC	1
26	8.307.634	Panel zadní kov P200AC-DC	Metal Rear Panel For Output P200AC-DC	1
27	7.232.022	Vypínač Pegas P200AC-DC	Switch On/OFF Pegas P200AC-DC	1
28+ 29	7.155.001	Průchodka P250	Cable Connector P250	1
30	8.122.366	Panel pro ventilátor P200AC-DC	Metal Panel For Fan P200AC-DC	1
31	7.253.013	Ventil Pegas	Solenoid Valve Pegas	1
32	7.720.030	Ventilátor P250	Fan P250	1
A-1	8.425.502	Chladič 3 P200AC-DC	Heat Sink 3 P200AC-DC	1
A-2	8.746.030	Box chladiče 2 P200AC-DC	Heat Sink Box 2 P200AC-DC	1
A-3	8.425.503	Chladič 4 P200AC-DC	Heat Sink 4 P200AC-DC	1
A-4	7.445.311	Rezistor 6ohm P200AC-DC	Rezistor 6ohm P200AC-DC	2
A-5	7.231.275	Termostat PEGAS	Thermo switch	2
A-6	7.425.631	Tranzistor IGBT Discrete1 P40	Discrete1 IGBT P40	8
A-6	7.425.631	Tranzistor IGBT Discrete1 P40	Discrete1 IGBT P40	4
A-7	7.421.681	Dioda P200AC-DC	Diode P200AC-DC	2
A-8	5.496.674-C	PCB silová P200AC-DC	PCB Power P200AC-DC	1
A-9	8.306.301	Krycí deska 1 P200AC-DC	Blanking plate 1 P200AC-DC	1
B-1	8.425.500	Chladič 2 P200AC-DC	Heat Sink 2 P200AC-DC	1
B-2	8.425.501	Chladič 1 P200AC-DC	Heat Sink 1 P200AC-DC	1
B-3	8.746.029-D	Box chladiče 1 P200AC-DC	Heat Sink Box 1 P200AC-DC	1
B-4	7.411.010	Usměrňovač PEGAS 160 E	Rectifier Bridge	2
B-5	5.496.527-B	Vstupní usměrňovač PCB P200AC-DC	Input rectifier PCB P200AC-DC	1

<b>B-6</b>	7.460.801	<b>Kondenzátor kapacitní P200P AC-DC</b>	<b>Capacitor P200P AC-DC</b>	6
<b>B-7</b>	8.052.500	<b>Krycí deska 2 P200AC-DC</b>	<b>Blanking plate 2 P200AC-DC</b>	1

#### 4. TROUBLESHOOTING

S/N	Troubles		Reasons	Solutions
1	Turn on the power source, and fan works, but the power pilot lamp is not on.		The power light damaged or connection is not good	Check and repair Pr7
			The transformer of power is broken	Repair or change the transformer
			Control PCB failures	Repair or change the control Pr4
2	Turn on the power source, and the power pilot lamp is on, but fan doesn't work		There is something in the fan	Clear out
			The start capacitor of fan damaged	Change capacitor
			The fan motor damaged	Change fan
3	Turn on the power source, the power pilot lamp is not on, and fan doesn't work		No power supply input	Check whether there is power supply
			The fuse inside the machine damaged	Change it (3A)
4	The number on the display is not intact.		The LED in the display is broken	Change the LED
5	The max and min value displayed doesn't accord with the set value.		The max value is not accordant (refer to §3.1)	Adjust potentiometer Imin on the power board.
			The min value is not accordant (refer to §3.1)	Adjust potentiometer Imaxin the current meter.
6	No no-load voltage output (MMA)		The machine is damaged	Check the main circuit and the Pr4.
7	Arc can not be ignited (TIG)	There is spark on the HF igniting board.	The welding cable is not connected with the two output of the welder.	Connect the welding cable to the welder's output.
			The welding cable damaged.	Repair or change it.
			The earth cable connected unstably.	Check the earth cable.
			The welding cable is too long.	Use an appropriate welding cable.
			There is oil or dust on the workpiece.	Check and remove it.
			The distance between tungsten electrode and workpiece is too long.	Reduce the distance (about 3mm).
		There is not spark on the HF igniting board.	The HF igniting board does not work.	Repair or change Pr8
			The distance between the discharger is too short.	Adjust this distance (about 0.7mm).
			The malfunction of the welding gun switch.	Check the welding gun switch, control cable and aero socket.

8	No gas flow (TIG)	Gas cylinder is close or gas pressure is low		Open or change the gas cylinder	
		Something in the valve		Remove it	
		Electromagnetic valve is damaged		Change it	
9	Gas always flows	The gas-test on the front panel is on		The gas-test on the front panel is off	
		Something in the valve		Remove it	
		Electromagnetic valve is damaged		Change it	
		The adjustment knob of pre-gas time on the front panel is damaged		Repair or change it	
10	The welding current can not be adjusted	The welding current potentiometer on the front panel connection is not good or damaged		Repair or change the potentiometer	
11	No AC output while selecting "AC"	The power PCB is in trouble.		Repair or change it.	
		The AC drive PCB damaged.		Change it.	
		The AC IGBT module damaged.		Change it.	
12	The welding current displayed isn't accordant with the actual value.	The min value displayed isn't accordant with the actual value. (Please refer to §3.1)		Adjust potentiometer Imin on the power board.	
		The max value displayed isn't accordant with the actual value. (Please refer to §3.1)		Adjust potentiometer Imax on the power board.	
13	The penetration of molten pool is not enough.	The welding current is adjusted too low		Increase the welding current	
		The arc is too long in the welding process		Use 2T operation	
14	The alarm light on the front panel is on	Over heat protection	Two much welding current	Reduce the welding current output	
			Working time too long	Reduce the duty cycle (work intermittently)	
		Over-voltage protection	Power supply fluctuates		Using the stable power supply
			Low-voltage protection	Power supply fluctuates	
		Too many machines using power supply in the same time		Reduce the machines using power supply in the same time	
		Over-current protection	Unusual current in the main circuit		Check and repair the main circuit and drive Pr6

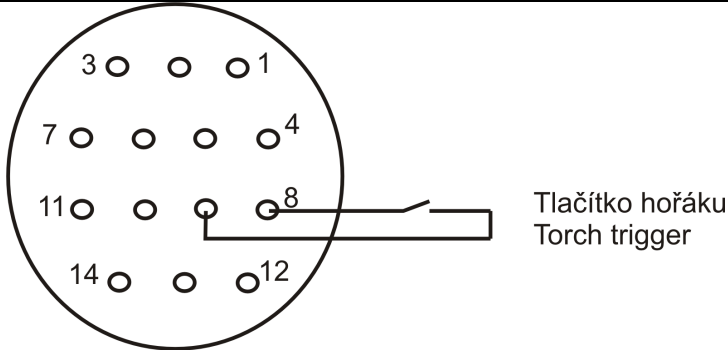
5. Konektor			Connector	
5.0189 Sada konektorů pro PEGAS AC/DC AERO			5.0189 Set of Connectors for PEGAS AC/DC AERO	
Image	Kód	CZ	EN	Quantity
	5.0181	PIN pro konektor PEGAS DOV Male	AERO plug Male PIN	2
	5.0179	Konektor PEGAS AERO čelo	AERO Plug PEGAS part 1	1
	5.0180	Konektor PEGAS AERO kryt	AERO plug PEGAS part 2	1
	5.0182	Připojení plynu PEGAS AC/DC matice převlečná	Gas fitting part 1 PEGAS AC/DC	1
	5.0183	Připojení plynu PEGAS AC/DC koncovka	Gas fitting part 2 PEGAS AC/DC	1
	5.0184	Připojení plynu PEGAS AC/DC matice zajišťovací	Gas fitting part 3 PEGAS AC/DC	1
Sada 5.0198 obsahuje pouze dva piny. Pro zapojení různých druhů dálkového ovládání budete potřebovat více pinů. Viz schémata níže.			The set 5.0198 content two pieces of PINs. In order to connect different kinds of remote controls you will need order more PINs. See the schemas below.	
6. Hořák			Torch	
				
7. Hořák s potenciometrem - nepodporováno			Torch with potentiometer – not supported	

8. Dálkové ovládání + hořák	Remote Control + torch
<p>Potenciometr Potenciometer 14K</p> <p>Tlačítko hořáku Torch trigger</p>	
9. Nožní dálkové ovládání-pedál	Remote foot control
<p>Potenciometr Potenciometer 14K</p> <p>Spínač pedálu Pedal trigger</p>	
10. Hořák s UD & DOWN	Torch with UD & DOWN
<p>Tlačítko/Torch UP &amp; DOWN</p> <p>Tlačítko hořáku Torch trigger</p>	
11. Zapojení plynového konektoru	Gas connector



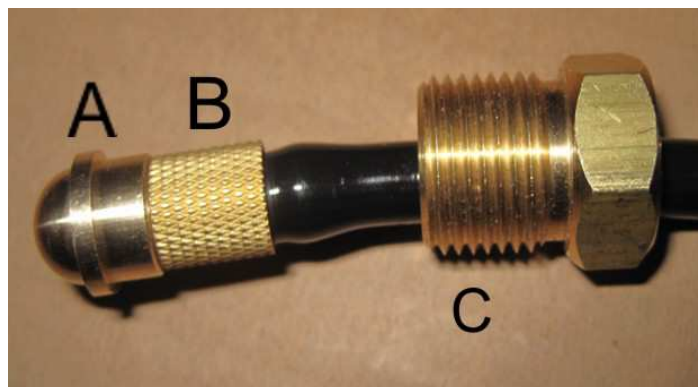

1. Na plynovou hadici nasadte dílec C
2. Sešroubujte dílec A a B
3. Nasadte trn z dílce A do hadice
4. Pevně utáhněte dílec B, tak, že vznikne mezera mezi osazením dílce A a dílcem B. Tím se zajistí hadice (viz obr. Níže).

1. Fit C onto the hose
2. Screw A and B together
3. Fit the nipple of A into the hose
4. Firmly tighten B in the way that between A and B appears a gap. That way you fix the hose (see the image below)

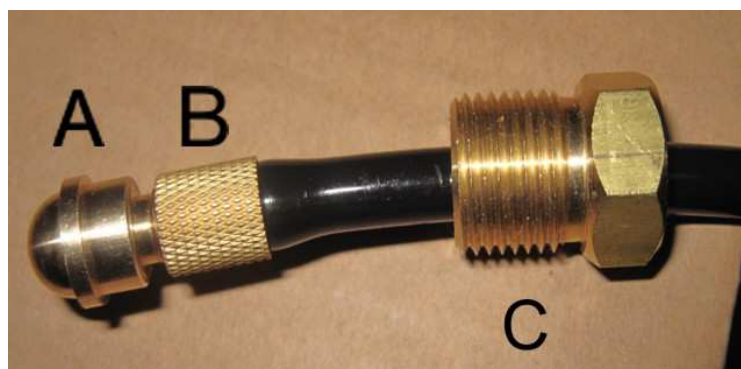

Worked out:	DJ 4/11/2011	Revision:	Vh 4/7/2012	Approved:	vh 4/7/2012
-------------	--------------	-----------	-------------	-----------	-------------