

SERVISNÍ MANUÁL PEGAS 200 AC-DC PULSE OVO	SERVICE MANUAL PEGAS 200 AC-DC PULSE OVO
	
1. VAROVÁNÍ	WARNING
<p><b>UPOZORNĚNÍ – Pouze osoba splňující kvalifikaci danou zákonem je oprávněna opravovat stroj.</b></p> <p><b>PŘED OTEVŘENÍM KRYTU STROJE JEJ ODPOJTE VYTAŽENÍM SÍTOVÉ VIDLICE ZE SÍTĚ.</b></p> <p><b>Každé 4 měsíce otevřete stroj a jemně ho vyfoukejte stlačeným suchým vzduchem POZOR, NEPOUŽÍVEJTE STLAČENÝ VZDUCH O PŘÍLIŠ VYSOKÉM TLAKU, ABY NEDOŠLO K MECHANICKÉMU POŠKOZENÍ ELEKTROSOUČÁSTEK.</b></p> <p><b>Každé 4 měsíce zkontrolujte řádný stav svařovacích kabelů a síťových kabelů.</b></p> <p><b>Není povolena žádná modifikace svařovacího stroje.</b></p> <p><b>Pro Vaši bezpečnost je nutné posečkat se sundáním krytu ze stroje po odpojení ze sítě po dobu minimálně 5 minut, kdy klesne napětí na kondenzátorech na hodnotu pod 36 V.</b></p>	<p><b>NOTE Only trained personnel are permitted to work inside the machine.</b></p> <p><b>BEFORE OPENING THE MACHINE, CUT OFF ITS ELECTRICAL POWER BY REMOVING THE PLUG FROM THE MAINS SUPPLY SOCKET.</b></p> <p><b>Every six months, open the machine and clean it inside, using compressed dehumidified air. CAUTION. DO NOT USE COMPRESSED AIR AT TOO HIGH A PRESSURE. YOU COULD DAMAGE THE ELECTRONIC COMPONENTS.</b></p> <p><b>With the same frequency, check the welding cables and the supply cables.</b></p> <p><b>No modification, of any type, may be made to the welding machine.</b></p> <p><b>For safety while maintaining the machine, please shut off the supply power and wait for 5 minutes, until capacity voltage already drops to safe voltage 36V.</b></p>
2. BLOKOVÉ SCHÉMA	ELECTRICAL PRINCIPLE DRAWING

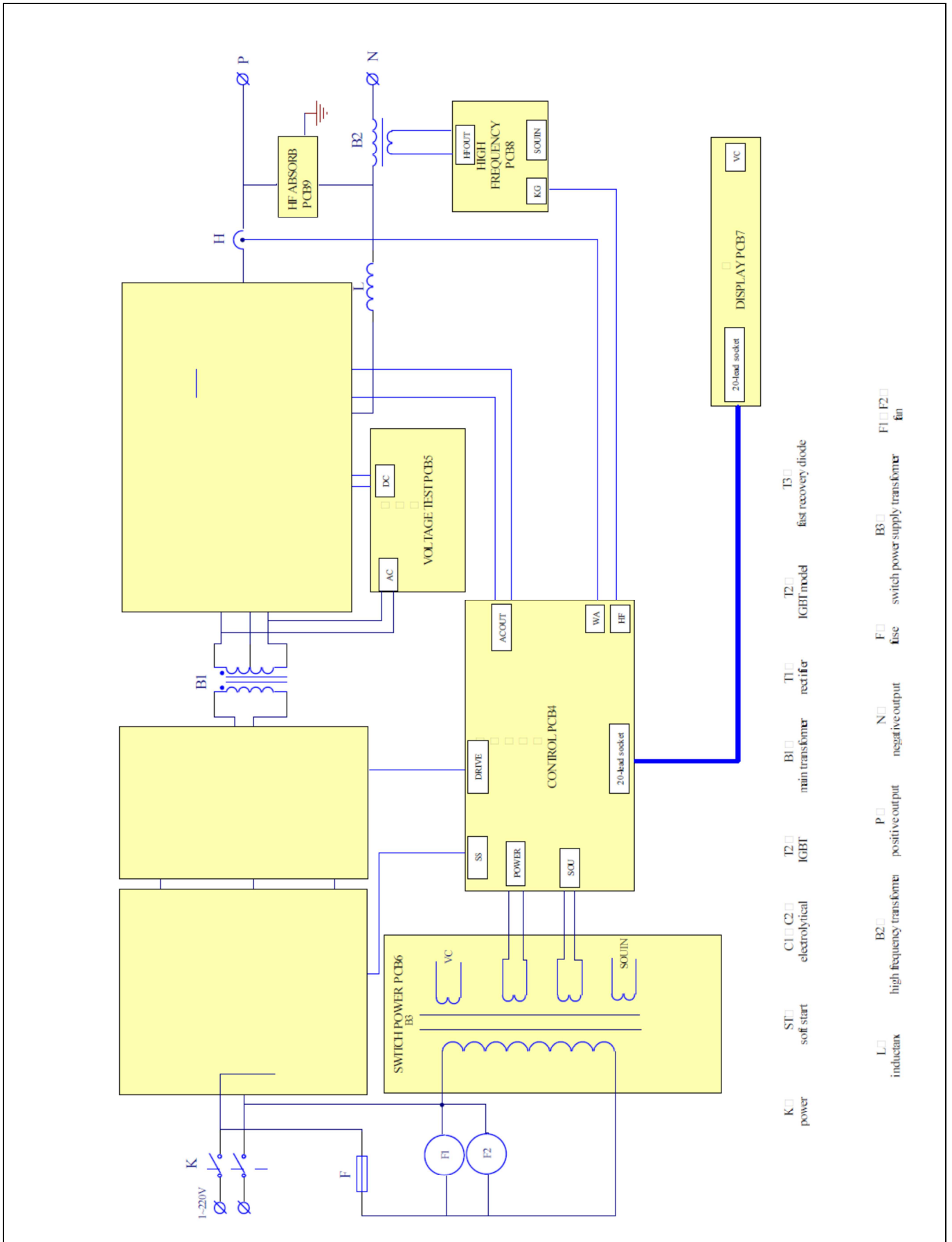

## 3. NÁHRADNÍ DÍLY

## SPARE PARTS

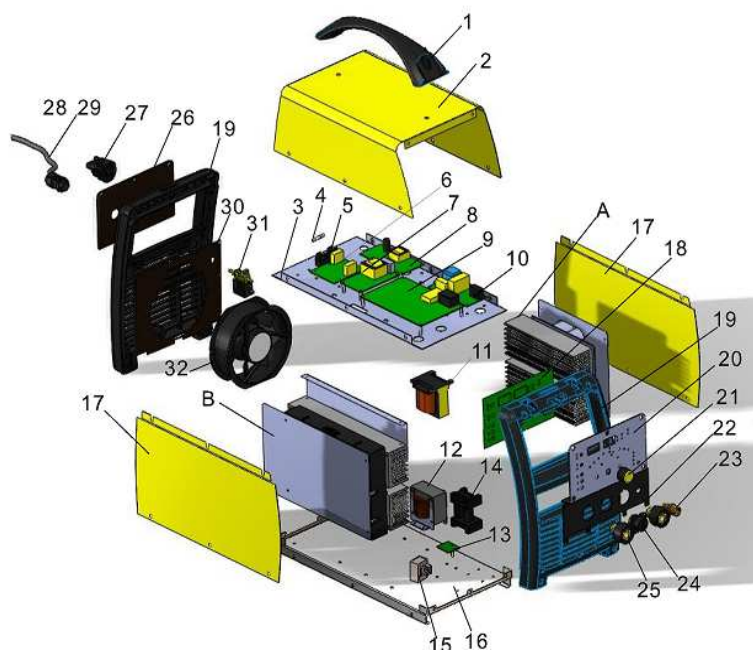

A

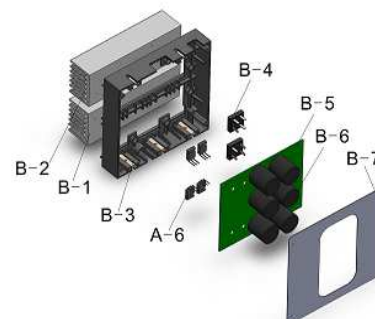

B

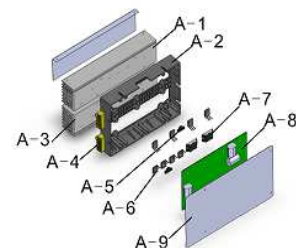

Pozice	Registrační číslo	Název 1	Description	Min. počet ks při obj.
1	8.253.035	Držák - madlo P200 OVO	Handle P200 OVO	1
2	8.301.001	Kryt horní P200 OVO	Upper Cover P200 OVO	1
3	8.062.519	Panel střední P200 OVO	Middle panel P200 OVO	1
4	7.202.123	Pojistka 3A	Fuse 3A	1
5	7.202.029	Držák pojistek P200AC-DC	Fuse Holder P200AC-DC	1
6	5.496.931	PCB EMC P200AC-DC	PCB EMC P200AC-DC	1
7	5.496.526-B	Zdroj spínaný PCB P200AC-DC	SWITCH POWER PCB P200AC-DC	1
8	5.496.875-E	PCB měření napětí	Voltage test PCB P200AC-DC	1
9	5.496.415-E	PCB řídicí P200P AC-DC	Control PCB P200P AC-DC	1
10	5.496.373-C	PCB HF P200AC-DC	PCB HF P200AC-DC	1
11	6.185.515	Transformátor hlavní	Main transformer P200AC-	1

		P200AC-DC	DC	
12	6.271.515	Tlumivka P200AC-DC	Choke P200AC-DC	1
13	5.496.204-B	HF filtr PCB P200P AC-DC	HF filter PCB P200P AC-DC	1
14	6.174.515	Trafo HF P200AC-DC	Transformer HF P200AC-DC	1
15	7.321.002	Sonda Hall 200A Pegas	Hall sensor 200A Pegas	1
16	8.055.519	Kryt spodní P200 OVO	Bottom Plate P200 OVO	1
17	8.050.008	Kryt boční P200 OVO	Side Cover P200 OVO	1
18	5.496.416-B	PCB přední P200P AC-DC	Front PCB P200P AC-DC	1
19	8.069.004	Panel přední plast P200 OVO	Plastic Front Panel	1
	8.068.004-B	Panel zadní plast P200 OVO	Plastic Rear Panel	1
20	8.306.441	Panel přední kov P200P AC-DC+fólie	Metal Front Panel P200P AC-DC+fólie	1
21	7.458.053	Knoflík Pegas černý P200P	Knob Pegas black P200P	1
22	8.065.570	Panel přední kov spodní P200AC-DC	Metal Front Panel For Output P200AC-DC	1
23	7.152.312	35-70mm Socket P250	Rychlosp. 35-70mm P250	1
24	7.132.114	Konektor zásuvka P250	14-Pin Socket P250	1
25	8.462.104	Konektor plyn Pegas P200AC-DC	Gas Connector Pegas P200AC-DC	1
26	8.307.634	Panel zadní kov P200AC-DC	Metal Rear Panel For Output P200AC-DC	1
27	7.232.022	Vypínač Pegas P200AC-DC	Switch On/OFF Pegas P200AC-DC	1
28	7.155.001	Průchodka P250	Cable Connector P250	1
29	7.154.402	Kabel přívodní Pegas	Mains Cable Pegas	1
30	8.122.366	Panel pro ventilátor P200AC-DC	Metal Panel For Fan P200AC-DC	1
31	7.253.013	Ventil Pegas	Solenoid Valve Pegas	1
32	7.720.030	Ventilátor P250	Fan P250	1
A--1	8.425.500	Chladič 2 P200AC-DC	Heat Sink 2 P200AC-DC	1
A--2	8.746.030	Box chladiče 2 P200AC-DC	Heat Sink Box 2 P200AC-DC	1
A--3	8.425.501	Chladič 1 P200AC-DC	Heat Sink 1 P200AC-DC	1
A--4	7.445.311	Rezistor 6ohm P200AC-DC	Rezistor 6ohm P200AC-DC	1
A--5	7.231.275	Termostat PEGAS	Thermo switch	1
A--6	7.425.631	Tranzistor IGBT Discrete1 P40	Discrete1 IGBT P40	1







A--7	7.421.681	Dioda P200AC-DC	Diode P200AC-DC	1
A--8	5.496.674-C	PCB silová P200AC-DC	PCB Power P200AC-DC	1
A--9	8.306.301	Deska krycí 1 P200AC-DC	Blanking plate 1 P200AC-DC	1
B--1	8.425.503	Chladič 4 P200AC-DC	Heat Sink 4 P200AC-DC	1
B--2	8.425.502	Chladič 3 P200AC-DC	Heat Sink 3 P200AC-DC	1
B--3	8.746.029-D	Box chladiče 1 P200AC-DC	Heat Sink Box 1 P200AC-DC	1
B--4	7.411.010	Usměrňovač PEGAS 160 E	Rectifier Bridge	1
B--5	5.496.527-B	Usměrňovač vstupní PCB P200AC-DC	Input rectifier PCB P200AC-DC	1
B--6	7.460.801	Kondenzátor kapacitní P200P AC-DC	Capacitor P200P AC-DC	1
B--7	8.052.500	Deska krycí 2 P200AC-DC	Blanking plate 2 P200AC-DC	1



#### 4. TROUBLESHOOTING

S/N	Troubles	Reasons	Solutions
1	Turn on the power source, and fan works, but the power pilot lamp is not on.	The power light damaged or connection is not good	Check and repair Pr7
		The transformer of power is broken	Repair or change the transformer
		Control PCB failures	Repair or change the control Pr4
2	Turn on the power source, and the power pilot lamp is on, but fan doesn't work	There is something in the fan	Clear out
		The start capacitor of fan damaged	Change capacitor
		The fan motor damaged	Change fan
3	Turn on the power source, the power pilot lamp is not on, and fan doesn't work	No power supply input	Check whether there is power supply
		The fuse inside the machine damaged	Change it (3A)
4	The number on the display is not intact.	The LED in the display is broken	Change the LED
5	The max and min value displayed doesn't accord with the set value.	The max value is not accordant (refer to §3.1)	Adjust potentiometer Imin on the power board.
		The min value is not accordant (refer to §3.1)	Adjust potentiometer Imaxin the current meter.
6	No no-load voltage output (MMA)	The machine is damaged	Check the main circuit and the Pr4.

7	Arc can not be ignited (TIG)	There is spark on the HF igniting board.	The welding cable is not connected with the two output of the welder.	Connect the welding cable to the welder's output.
			The welding cable damaged.	Repair or change it.
			The earth cable connected unstably.	Check the earth cable.
			The welding cable is too long.	Use an appropriate welding cable.
			There is oil or dust on the workpiece.	Check and remove it.
			The distance between tungsten electrode and workpiece is too long.	Reduce the distance (about 3mm).
	There is not spark on the HF igniting board.	The HF igniting board does not work.	Repair or change Pr8	
		The distance between the discharger is too short.	Adjust this distance (about 0.7mm).	
8	No gas flow (TIG)	Gas cylinder is close or gas pressure is low	Open or change the gas cylinder	
		Something in the valve	Remove it	
		Electromagnetic valve is damaged	Change it	
9	Gas always flows	The gas-test on the front panel is on	The gas-test on the front panel is off	
		Something in the valve	Remove it	
		Electromagnetic valve is damaged	Change it	
		The adjustment knob of pre-gas time on the front panel is damaged	Repair or change it	
10	The welding current can not be adjusted	The welding current potentiometer on the front panel connection is not good or damaged	Repair or change the potentiometer	
11	No AC output while selecting "AC"	The power PCB is in trouble.	Repair or change it.	
		The AC drive PCB damaged.	Change it.	
		The AC IGBT module damaged.	Change it.	
12	The welding current displayed isn't accordant with the actual value.	The min value displayed isn't accordant with the actual value. (Please refer to § 3.1)	Adjust potentiometer Imin on the power board.	
		The max value displayed isn't accordant with the actual value. (Please refer to § 3.1)	Adjust potentiometer Imax on the power board.	
13	The penetration of molten pool is not enough.	The welding current is adjusted too low	Increase the welding current	
		The arc is too long in the welding process	Use 2T operation	
14	The alarm light on the front panel is on	Over heat protecti	Two much welding current	Reduce the welding current output

		on	Working time too long	Reduce the duty cycle (work intermittently)
		Over-voltage protection	Power supply fluctuates	Using the stable power supply
		Low-voltage protection	Power supply fluctuates	Using the stable power supply
			Too many machines using power supply in the same time	Reduce the machines using power supply in the same time
		Over-current protection	Unusual current in the main circuit	Check and repair the main circuit and drive Pr6

5. Konektory pro hořák			Torch Connectors	
5.0189 Sada konektorů pro PEGAS AC/DC AERO			5.0189 Set of Connectors for PEGAS AC/DC AERO	
Image	Kód	CZ	EN	Quantity
	5.0181	PIN pro konektor PEGAS DOV Male	AERO plug Male PIN	2
	5.0179	Konektor PEGAS AERO čelo	AERO Plug PEGAS part1	1
	5.0180	Konektor PEGAS AERO kryt	AERO plug PEGAS part 2	1
	5.0182	Připojení plynu PEGAS AC/DC matice převlečná	Gas fitting part 1 PEGAS AC/DC	1
	5.0183	Připojení plynu PEGAS AC/DC koncovka	Gas fitting part 2 PEGAS AC/DC	1
	5.0184	Připojení plynu PEGAS AC/DC matice zajišťovací	Gas fitting part 3 PEGAS AC/DC	1
Sada 5.0198 obsahuje pouze dva piny. Pro zapojení různých druhů dálkového ovládání budete potřebovat více pinů. Viz schémata níže.			The set 5.0198 content two pieces of PINs. In order to connect different kinds of remote controls you will need order more PINs. See the schemas below.	

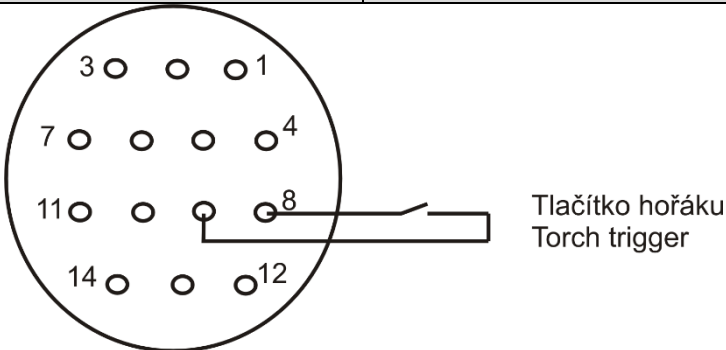
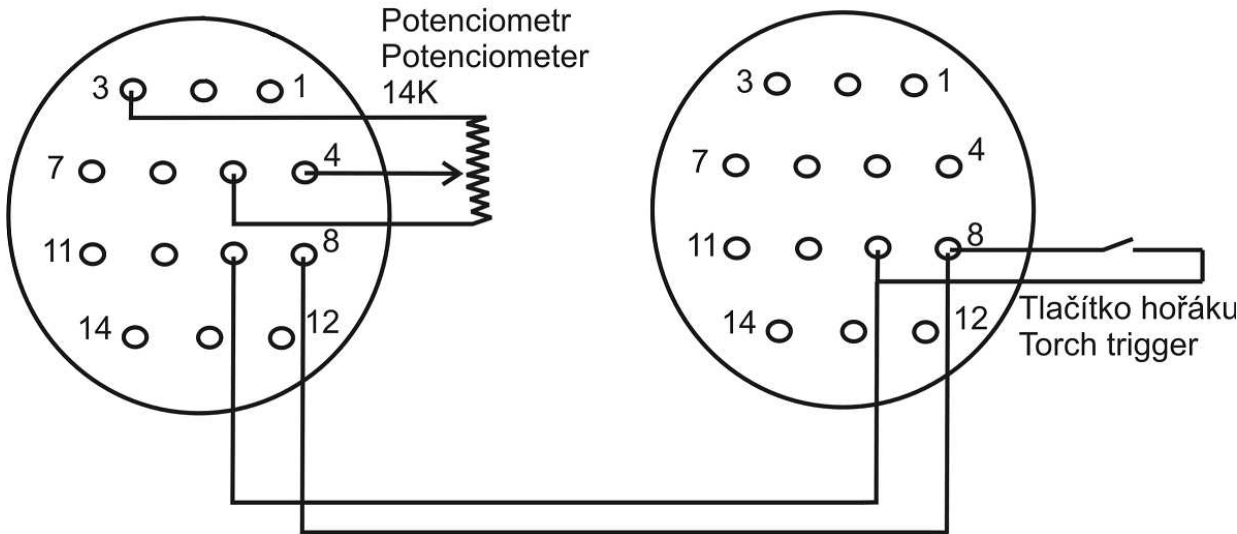
6. Konektory připojení plynu – zadní panel		Gas fittings for the rear panel		
Image	Kód	CZ	EN	Quantity
	BD-80210	Rychlospojka poz. 52	Quick Connector poz. 52	1
	AO-42620	Svorka D9.5	Clamp D9.5	1
<b>7. Hořák</b>		<b>Torch</b>		
				
<b>8. Hořák s potenciometrem - nepodporováno</b>		<b>Torch with potentiometer – not supported</b>		
<b>9. Dálkové ovládání + hořák</b>		<b>Remote Control + torch</b>		
				
<b>10. Nožní dálkové ovládání-pedál</b>		<b>Remote foot control</b>		

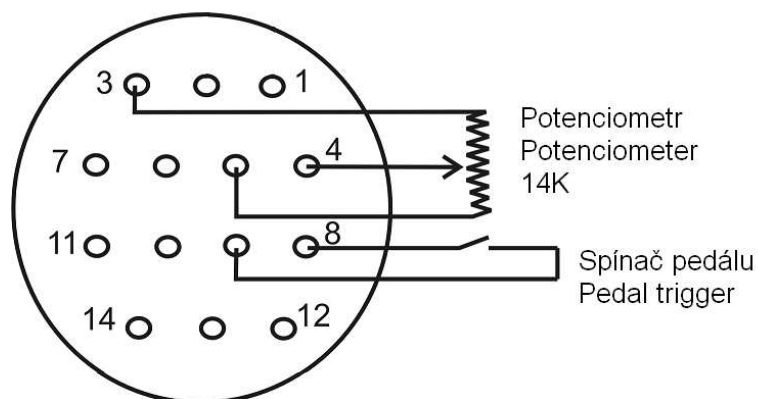
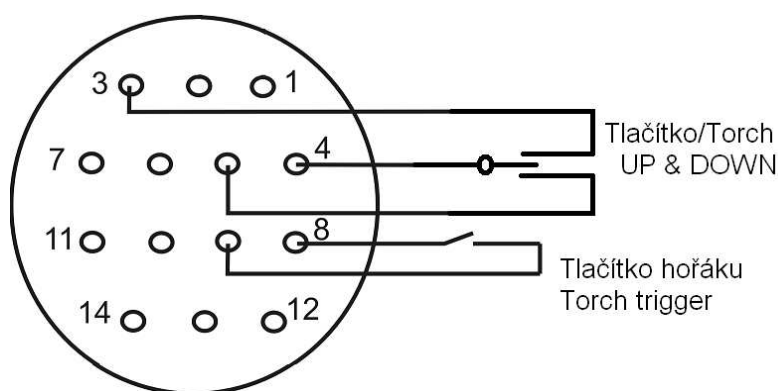
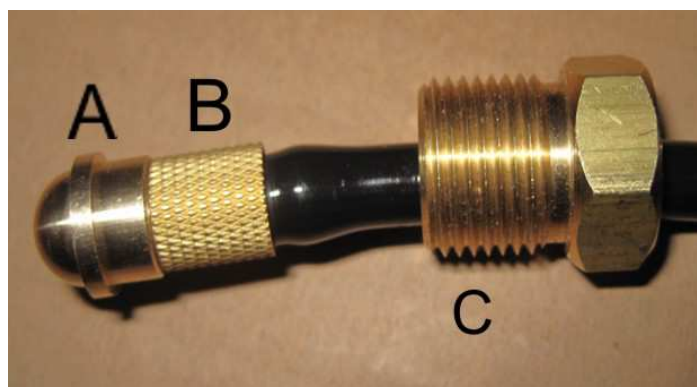

**10. Hořák s UD & DOWN****Torch with UD & DOWN****11. Zapojení plynového konektoru****Gas connector**

1. Na plynovou hadici nasadíte dílec C
2. Sešroubujte dílec A a B
3. Nasadíte trn z dílce A do hadice
4. Pevně utáhněte dílec B, tak, že vznikne mezera mezi osazením dílce A a dílcem B. Tím se zajistí hadice (viz obr. Níže).

1. Fit C onto the hose
2. Screw A and B together
3. Fit the nipple of A into the hose
4. Firmly tighten B in the way that between A and B appears a gap. That way you fix the hose (see the image below)

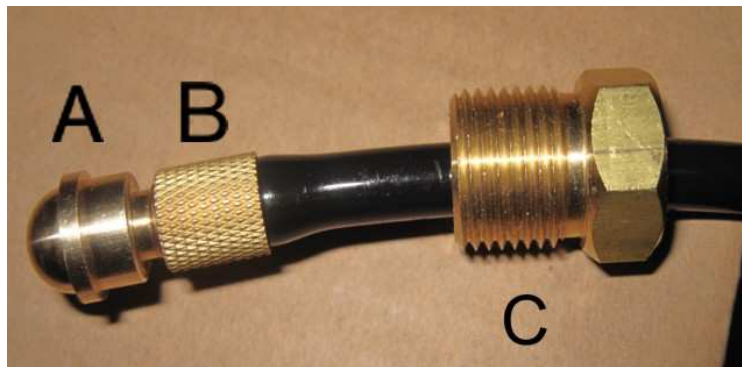

Worked out:	OF 18/10/2013	Revision:	vh 19/12/2013	Approved:	vh 19/12/2013
-------------	---------------	-----------	---------------	-----------	---------------