

**SERVISNÍ MANUÁL PEGAS 40
PLASMA PFC OVO**

**SERVICE MANUAL PEGAS 40
PLASMA PFC OVO**

1. BLOKOVÉ SCHÉMA

ELECTRICAL PRINCIPLE DRAWING

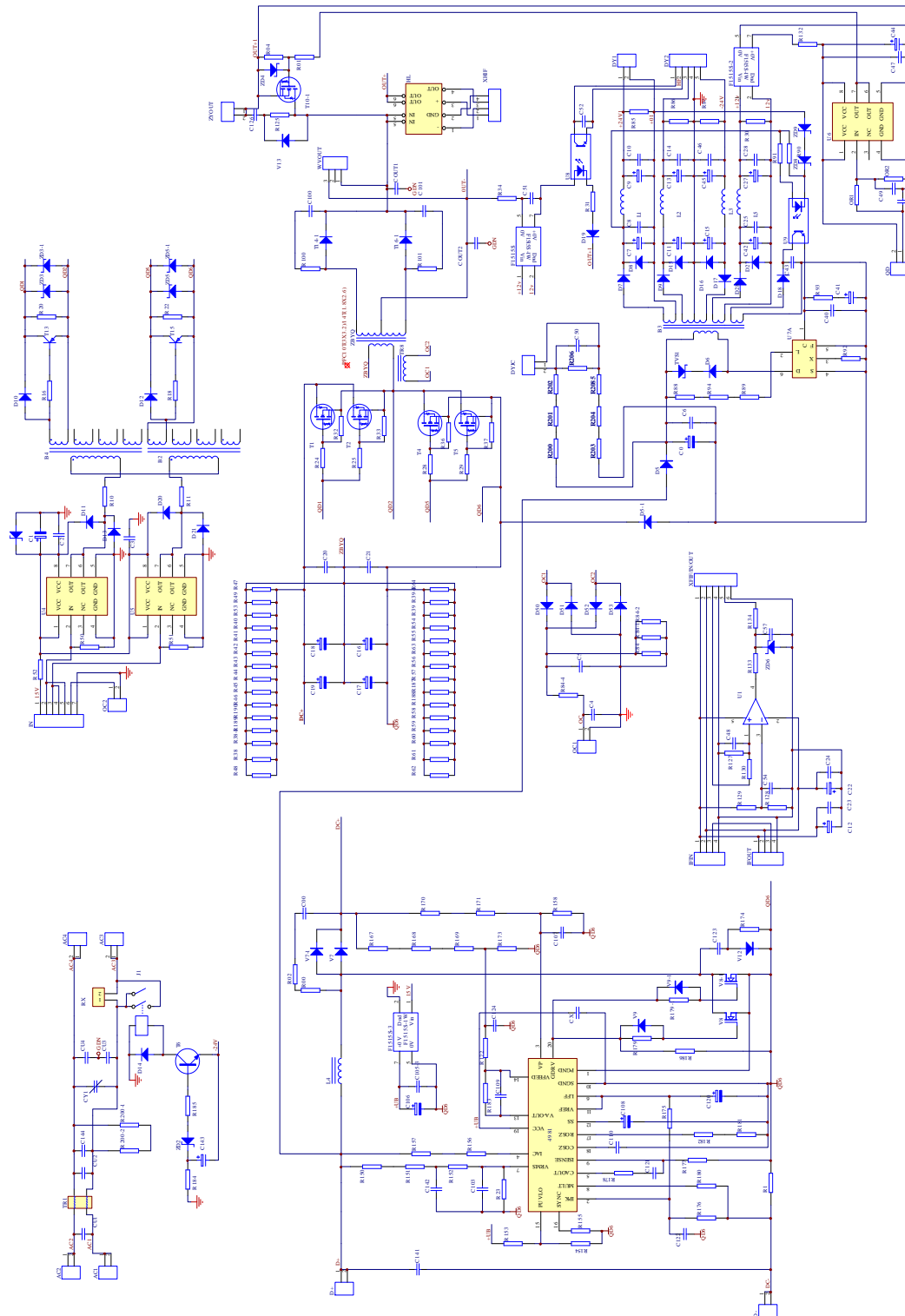

2. NÁHRADNÍ DÍLY

SPARE PARTS

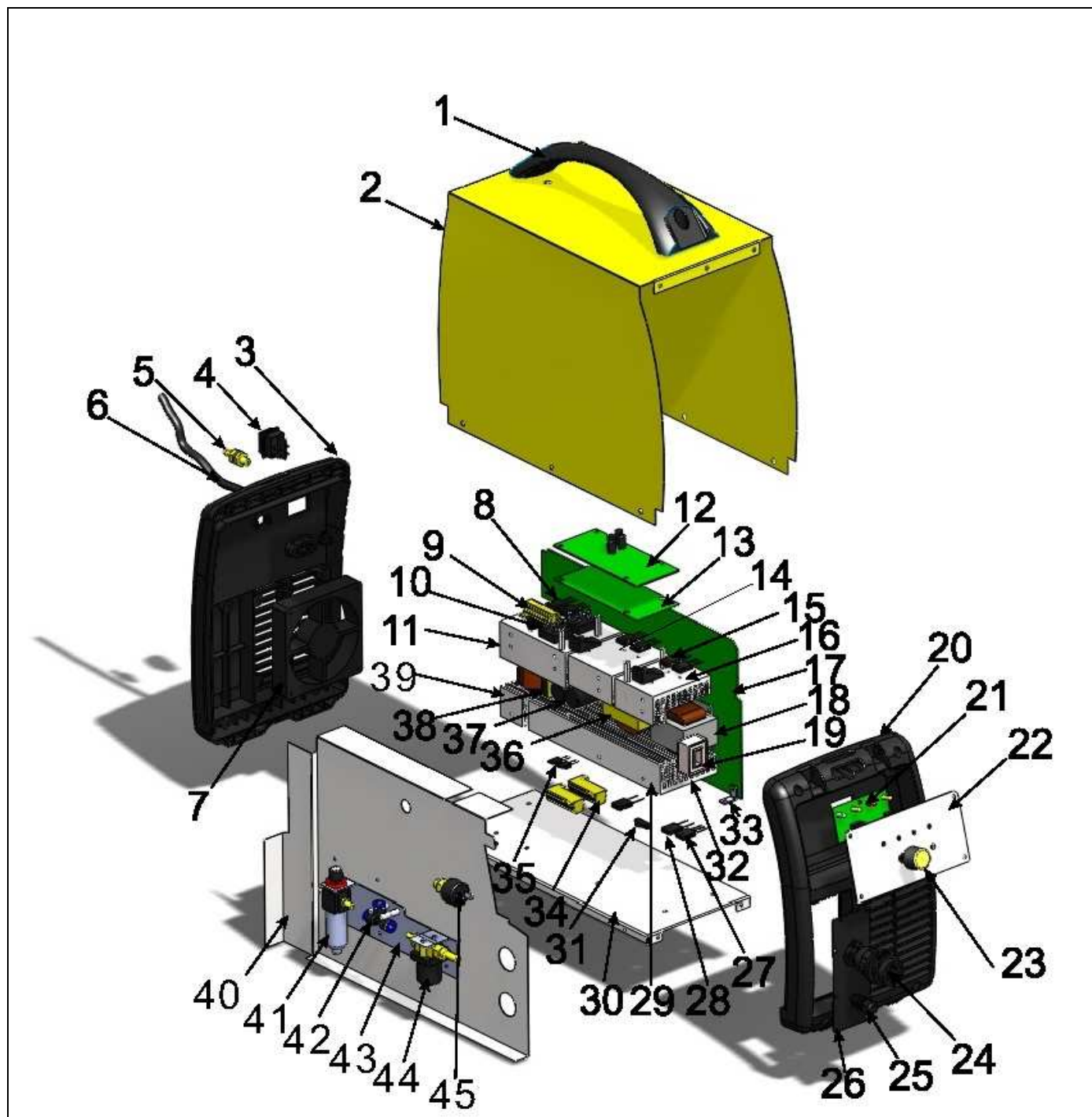

Pozice	Registrační číslo	Název 1	Description	Min. počet ks při obj.
1	8.253.029	Držák - madlo P40 OVO	Handle P40 OVO	1
2	8.301RM.649	Kryt horní P40 OVO	Cover upper P40 OVO	1
3	8.068.983-B	Panel zadní P40 OVO	Back Panel P40 OVO	1
4	7.232.730	Vypínač hlavní P40	Switch ON/OFF P40	1
5	8.462.116	Konektor vzduch P40	Air Connector P40	1
6	7.154.402	Kabel přívodní Pegas	Mains Cable Pegas	1
7	7.720.010	Ventilátor P40 OVO	Fan P40 OVO	1
8	7.425.632	Tranzistor IGBT Discrete PEGAS	Discrete IGBT	1

9	7.445.315	Rezistor P40 OVO	Resistor P40 OVO	1
10	7.411.010	Usměrňovač PEGAS 160 E	Rectifier Bridge	1
11	8.425.639	Chladič 1 P40	Heat sink 1 P40	1
12	5.496.604	PCB řídicí P40	PCB Control P40	1
14	8.425.640	Chladič 2 P40	Heat sink 2 P40	1
15	7.425.631	Tranzistor IGBT Discrete1 P40	Discrete1 IGBT P40	1
16	8.425.641	Chladič 3 P40	Heat sink 3 P40	1
17	5.496.110-R-7	PCB hlavní P40 OVO	Main board P40 OVO	1
17	5.AAA.40P OVO	PCB silová P40 OVO kompl.(Obsahuje položky 8+11+14+16-18+27-29+35-39)	PCB Power P40 OVO compl. (Contains items 8+11+14+16-18+27-29+35-39)	1
17	5.AAR.40P OVO	PCB silová P40 OVO kompl.Repas(Obsahuje položky 8+11+14+16-18+27-29+35-39)	PCB Power P40 OVO compl.Repair. (Contains items 8+11+14+16-18+27-29+35-39)	1
18	6.271.639	Tlumivka P40	Inductance P40	1
19	7.321.104	Sonda Hall P40 OVO	Hall sensor P40 OVO	1
20	8.069RM.906	Panel přední P40 OVO	Front plastic panel P40 OVO	1
21	5.496.803-E	PCB přední P40	PCB Front P40	1
22	8.123RM.026	Panel přední kov P40 OVO	Metal Front Panel P40 OVO	1
23	7.458.033-C	Knoflík Pegas černý	Knob Pegas black	1
24	7.667.001	Centrální koncovka hořáku CUT P40	CENTRAL OUTLET CUT P40	1
25	7.155.141	Vývodka P40 OVO	Outlet P40 OVO	1
26	8.123RM.031	Výstupní panel P40 OVO	Output panel P40 OVO	1
27	7.425.634	Tranzistor IGBT Discrete2 P40	IGBT Discrete2 P40	1
28	7.421.541	Dioda PEGAS 160 E	Diode	1
29	8.425.642	Chladič 4 P40	Heat sink 4 P40	1
30	8.055RM.649	Kryt spodní P40 OVO	Base panel P40 OVO	1
31	7.231.275	Termostat PEGAS	Thermo switch	1
32	8.425.643	Chladič 5 P40	Heat sink 5 P40	1
33	8.123.641	Držák PCB Pegas P160P	Holder for PCB Pegas P160P	1
34	7.445.319	Rezistor 6,8ohm P40	Resistor 6,8ohm P40	1
35	7.401.070	Dioda P40 OVO	Diode P40 OVO	1
36	6.185.639	Trafo hlavní P40	Main transformer P40	1
37	7.460.790	Kondenzátor kapacitní P40	Capacitor P40	1
38	6.190.639	PFC P40	PFC P40	1
39	8.425.642	Chladič 4 P40	Heat sink 4 P40	1
40	8.303RM.649	Panel střední P40 OVO	Midle front P40 OVO	1

41	7.315.060-B	Redukce vzduchu P40 OVO	Reduction air P40 OVO	1
42	7.624.270	Šroubení "T" P40	CROSSES TEE BARBED "T" P40	1
43	8.123RM.030	Lišta P40 OVO	Metal panel P40 OVO	1
44	7.253.009-B	Ventil P40	Solenoid valve P40	1
45	7.232.637	Tlakový spínač P40	PREESSURE SWITCH P40	1

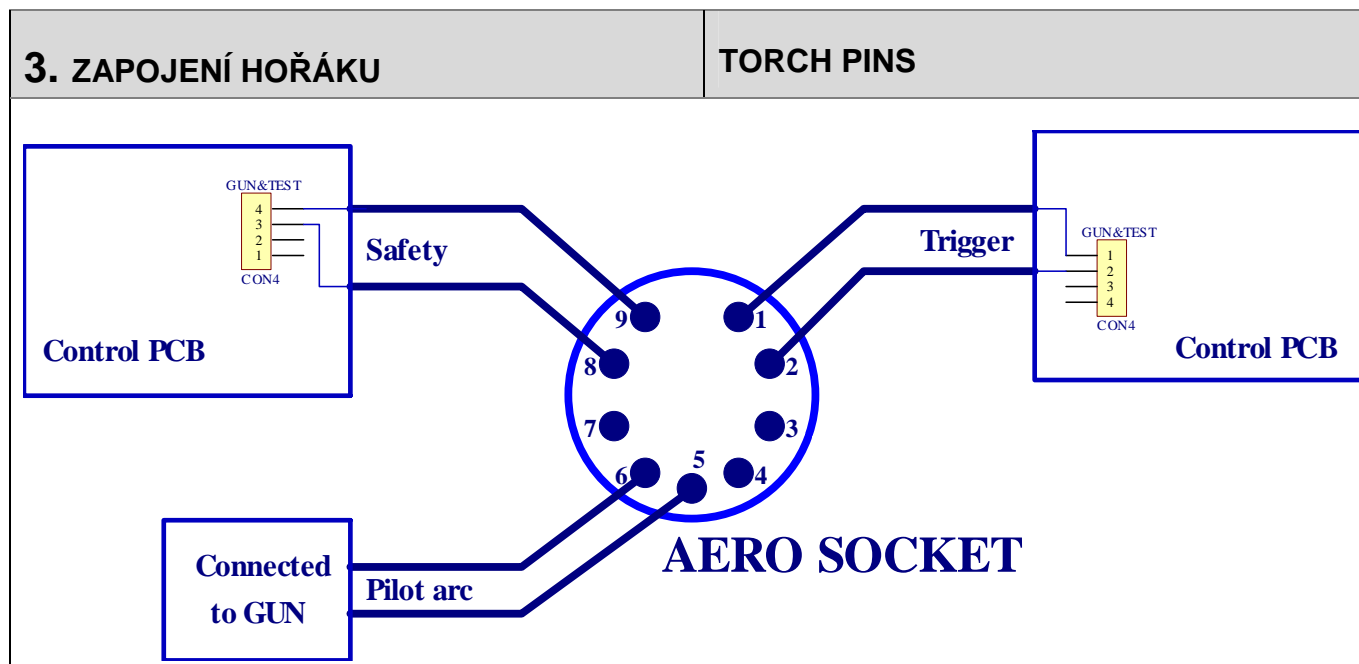

Worked out:	OF18/10/2013	Revision:	DJ 18/10/2013	Approved:	DJ 18/10/2013
-------------	--------------	-----------	---------------	-----------	---------------