

**SERVISNÍ MANUÁL ALFIN 281  
AC/DC**
**SERVICE MANUAL ALFIN 281  
AC/DC**

**1. VAROVÁNÍ**

**UPOZORNĚNÍ – Pouze osoba splňující kvalifikaci danou zákonem je oprávněna opravovat stroj.**

**PŘED OTEVŘENÍM KRYTU STROJE JEJ ODPOJTE VYTAŽENÍM SÍTOVÉ VIDLICE ZE SÍTĚ.**

**Každé 4 měsíce otevřete stroj a jemně ho vyfoukejte stlačeným suchým vzduchem  
POZOR, NEPOUŽÍVEJTE STLAČENÝ VZDUCH O PŘÍLIŠ VYSOKÉM TLAKU, ABY NEDOŠLO K MECHANICKÉMU POŠKOZENÍ ELEKTROSOUČÁSTEK.**

**Každé 4 měsíce zkontrolujte řádný stav svařovacích kabelů a síťových kabelů.**

**Není povolena žádná modifikace svařovacího stroje.**

**WARNING**

**NOTE Only trained personnel are permitted to work inside the machine.**

**BEFORE OPENING THE MACHINE, CUT OFF ITS ELECTRICAL POWER BY REMOVING THE PLUG FROM THE MAINS SUPPLY SOCKET.**

**Every six months, open the machine and clean it inside, using compressed dehumidified air.**

**CAUTION. DO NOT USE COMPRESSED AIR AT TOO HIGH A PRESSURE. YOU COULD DAMAGE THE ELECTRONIC COMPONENTS.**

**With the same frequency, check the welding cables and the supply cables.**

**No modification, of any type, may be**

<p><b>Pro Vaši bezpečnost je nutné posečkat se sundáním krytu ze stroje po odpojení ze sítě po dobu minimálně 5 minut, kdy klesne napětí na kondenzátorech na hodnotu pod 36 V.</b></p>	<p><b>made to the welding machine.</b></p> <p><b>For safety while maintaining the machine, please shut off the supply power and wait for 5 minutes, until capacity voltage already drops to safe voltage 36V.</b></p>
<p><b>2. BLOKOVÉ SCHÉMA</b></p>	<p><b>ELECTRICAL PRINCIPLE DRAWING</b></p>

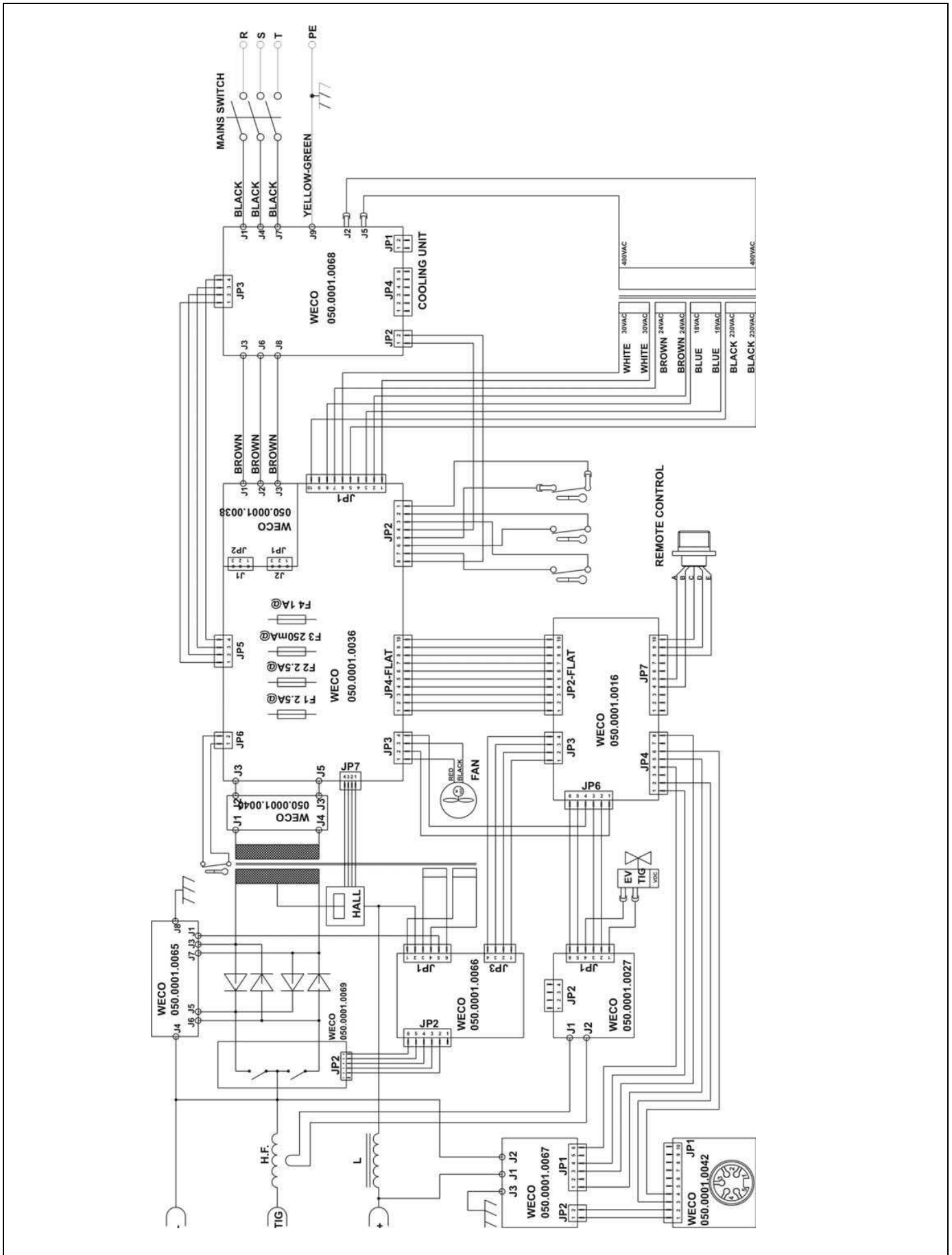

**Schéma zapojení DOV ALFIN 280/281 AC/DC**

**ELECTRICAL PRINCIPLE DOV ALFIN 280/281 AC/DC**

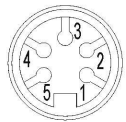

Konektor hořáku

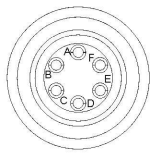
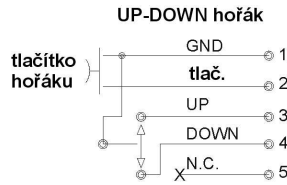
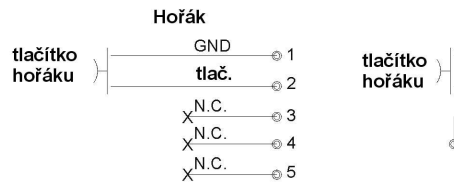

Konektor DOV

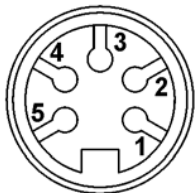
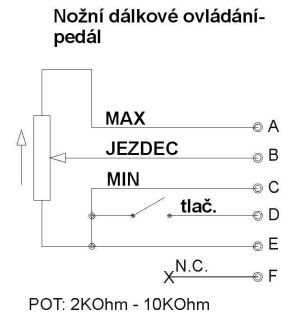
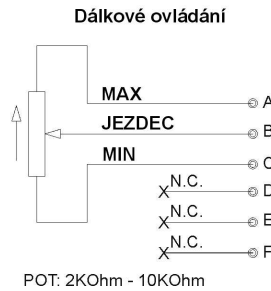
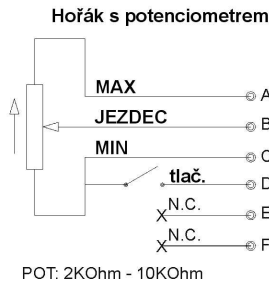

**CONNETTORE TORCIA  
TORCH CONNECTOR**

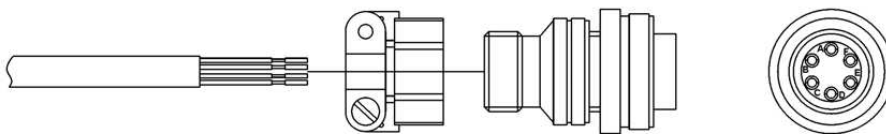
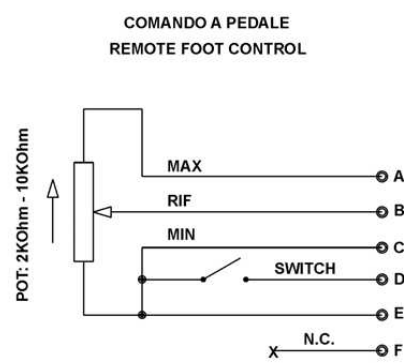
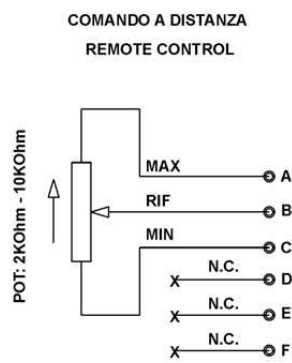
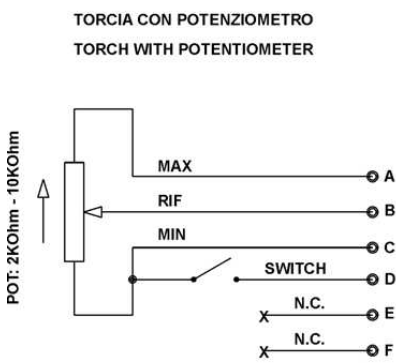
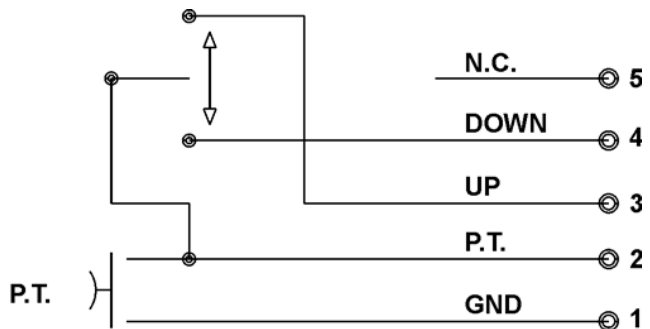

**3. NÁHRADNÍ DÍLY**

**SPARE PARTS**

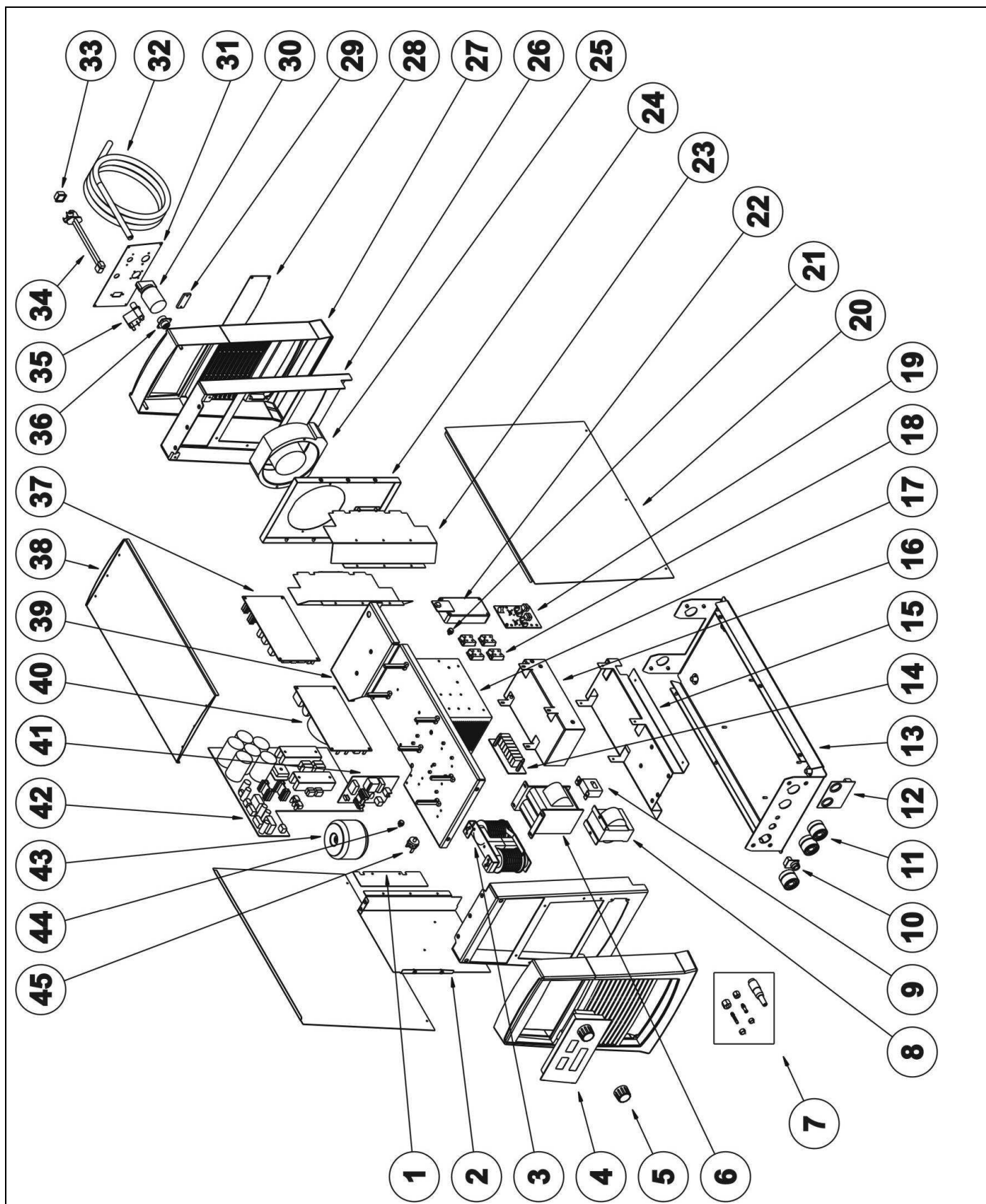

Poz.	Název	DESCRIPTION	CODE
1	Boční tlumící kryt	LATERAL HEAT SINK PLATE	011.0013.0011
2	Boční kryt	LATERAL PLATE	011.0013.0009
3	Trafo HF	H.F. TRANSFORMER	010.0002.0005
4	PCB řídicí	LOGIC FRONT PANEL	050.5152.0000
4	PCB řídicí	LOGIC FRONT PANEL	050.5152.0001
5	Knoflík kodér bez šipky	KNOB	014.0002.0010
6	Trafo silové	POWER TRANSFORMER	042.0003.0033
7	Sada pro připojení plynu	KIT FOR GAS CONNECTORS	021.0000.0001
8	Tlumivka	OUTPUT INDUCTANCE	044.0004.0004
9	Hallova sonda	HALL SENSOR	041.0004.0300
10	Konektor ovládací	AMPHENOL CONN. BOARD	050.0001.0042
11	Silová rychlospojka	FIXED SOCKET 400 A	021.0001.0259
12	PCB filtr	OUTPUT FILTER BOARD	050.0001.0067
13	Kryt spodní	LOWER COVER	011.0013.0001
14	PCB primární kondenzátory	CAPACITORS BOARD	050.0001.0040
15	Vnitřní držák	INTERNAL PLATE	011.0013.0002
16	Podpěra	HEAT SINK SUPPORT	011.0013.0003
17	Chladič	HEAT SINK	015.0001.0011
18	ISOTOP diody	DIODE	032.0002.2006
19	PCB tlumič	SNUBBER BOARD	050.0001.0065
20	Kryt boční	LATERAL COVER	011.0001.0511
21	Termostat L=300mm	TERMAL SWITCH L=300mm	040.0003.1170
22	PCB inverzní	INVERSION MODULE	050.0001.0069
23	Boční kryt ventilátoru	CONVEYOR PLATE	011.0013.0005
24	Držák ventilátoru	INTERNAL FAN SUPPORT	011.0013.0008
25	Ventilátor	FAN	003.0002.0004
26	Panel přední/zadní	FRONT/REAR PLATE	011.0013.0004
27	Panel přední/zadní (plast. výlisek)	FRONT/REAR PLASTIC PANEL	010.0006.0035
28	Panel zadní- krytka	REAR COVER PLATE	011.0013.0012
29	Vývodka	CABLE CLAMP	045.0000.0004
30	Hlavní vypínač	THREE-POLE SWITCH	040.0001.0015
31	Panel zadní	REAR PANEL	013.0018.0000
32	Kabel přívodní	SUPPLY CABLE	045.0002.0005
33	Krytka konektoru	ILME CONNECTOR CAP	021.0013.0007
34	Konektor CU 03/04, vodiče	CU 03/04 SUPPLY CABLE	022.0002.0073
35	Ventil plynový	SOLENOID VALVE	017.0001.5541

36	Konektor DOV, vodiče	REMOTE CONTROL WIRING	022.0002.0061
37	PCB inverzní	INVERSION BOARD	050.0001.0066
38	Kryt horní	UPPER COVER	011.0000.0501
39	Podpora horní	UPPER PLATE	011.0013.0006
40	PCB line filtr	LINE FILTER BOARD	050.0001.0068
41	PCB HF	H.F.BOARD	050.0001.0027
42	PCB silová	POWER BOARD	050.0001.0036
43	Ovládací trafo	TOROIDAL TRANSFORMER	041.0006.0002
44	Termostat L=200mm	TERMAL SWITCH L=200mm	040.0003.1270
45	Termostat	TERMAL SWITCH	040.0003.0060

**CS CU-04**

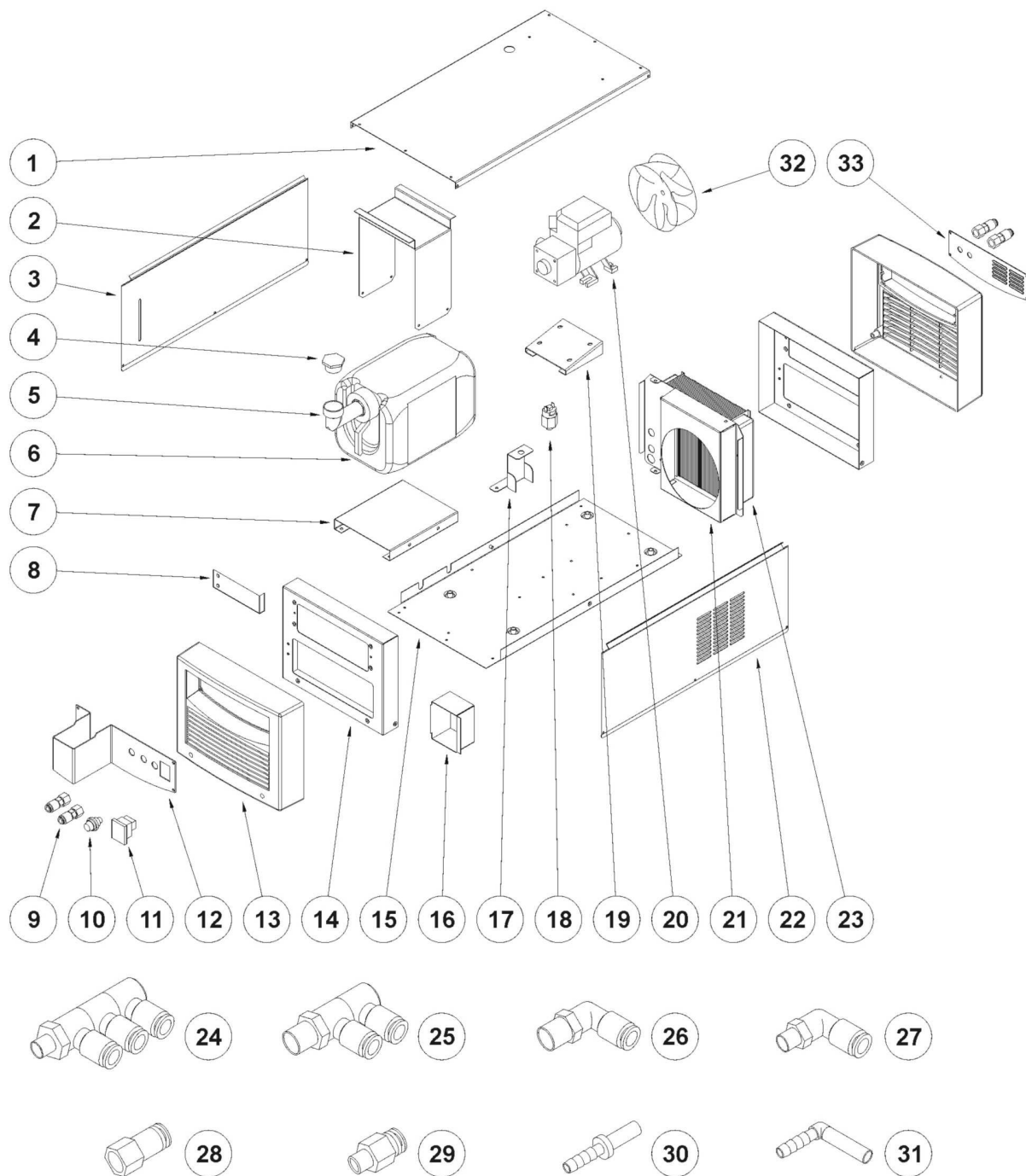



Poz.	Název	DESCRIPTION	CODE
1	Kryt horní	CASE	011.0012.0025
2	Držák nádržky	TANK CARTER	011.0012.0028
3	Levý kryt	LEFT SIDE	011.0000.0361
4	Zátka	PLUG	017.0003.1005
5	Hrdlo nádržky komplet	TANK FILLING COMPLETE PIPE UNION	010.0004.0120
6	Nádržka	TANK	010.0004.0111
7	Podstavec nádržky	TANK SUPPORT	011.0012.0027
8	Držák nádržky	TANK BLOCK	011.0012.0034
9	Rychlospojka	QUICK CLUTCH	018.0002.0004
10	Pojistka	FUSE CARRIER	040.0006.1880
11	Hlavní vypínač	SWITCH	040.0001.0003
12	Přední panel	FRONT PANEL	011.0012.0031
13	Přední panel- plast. výlisek	FRONT-BACK	012.0006.0010
14	Přední/zadní držák	FRONT-BACK SUPPORT	011.0012.0029
15	Dno	BASE	011.0012.0023
16	Krytka vypínače	SWITCH CASE	011.0012.0030
17	Držák tlakového spínače	PRESSURE SWITCH SUPPORT	011.0004.0003
18	Tlakový spínač	PRESSURE SWITCH	017.0006.0002
19	Držák čerpadla	PUMP SUPPORT	011.0012.0026
20	Čerpadlo	PUMP	003.0004.0004
21	Kryt vrtule	FAN CARTER	011.0012.0024
22	Pravý kryt	RIGHT SIDE	011.0000.0371
23	Chladič	RADIATOR	010.0004.0101
24	Rozbočka úhlová samec 3x 1/8 plyn.	TRIPLE MALE ELBOW 1/8 GAS	017.0003.0012
25	Rozbočka úhlová samec 2x 1/4 plyn.	DOUBLE MALE ELBOW 1/4 GAS	017.0003.0010
26	Kolínko samec 1/4 plyn.	MALE ELBOW 1/4 GAS	017.0003.0009
27	Kolínko samec 1/8 plyn.	MALE ELBOW 1/8 GAS	017.0003.0002
28	Konektor samice 1/8 plyn.	FEMALE CONNECTOR 1/8 GAS	017.0003.0011
29	Konektor samec 1/8 plyn.	MALE CONNECTOR 1/8 GAS	017.0003.0007
30	Přípojka rovná	TUBE TO HOSE STEM	017.5001.3010
31	Přípojka úhlová	TUBE TO HOSE ELBOW	017.5001.3011
32	Vrtule	FAN	003.0001.0009
33	Zadní panel	REAR PANEL	011.0012.0032

#### 4. ZÁVADY - ŘEŠENÍ

Poř.	Závada	Příčina	Řešení
1	Stroj je zapnutý, ventilátor funguje, LED zapnutí nesvídí	LED nebo její připojení je vadné.	Opravte připojení nebo vyměňte LED poř.4
		Silová PCB je vadná.	Opravte nebo vyměňte PCB poř.č42
2	Stroj je zapnutý, LED zapnutí svítí, ventilátor neběží.	Překážka rotace ventilátor.	Odstraňte
		Motor ventilátor poškozen.	Vyměňte ventilátor
3	Stroj je zapnutý, LED zapnutí nesvídí, ventilátor neběží.	Není napětí v síti	Zkontrolujte, jestli je v síti napětí.
		Přepětí nebo podpětí v síti.	Zkontrolujte síťové napětí.
4	Žádné napětí na prázdko	Závada generátor.	Zkontrolujte hlavní vypínač

5	Žádný svařovací proud na svorkách	Svařovací kabely nejsou připojeny do konektorů.	Připojte svařovací kabely do rychlospojek na stroji.	
		Poškozený svařovací kabel.	Vyměňte nebo opravte svařovací kabel.	
		Zemnicí kabel není připojen nebo je špatně připojen.	Zkontrolujte zemnicí kabel	
6	Obtížně se zapaluje oblouk nebo dochází k lepení elektrody.	Špatně utažené svařovací kabely.	Zkontrolujte utažení svařovacích kabelů.	
		Svařenec je znečištěn olejem nebo prachem.	Očistěte svařenec.	
		MMA/TIG výběr je špatný.	Vyberte MMA svařování.	
7	Nestabilní svařovací oblouk.	ARC FORCE nastaveno příliš nízké.	Zvyšte ARC FORCE.	
8	Svařovací proud nelze nastavit.	Poškozený potenciometr předního panelu.	Opravte nebo vyměňte potenciometr.	
9	Penetrace tavné lázně nedostačující.	Svařovací proud je nastaven příliš nízký.	Zvyšte svařovací proud	
		ARC FORCE nastaveno příliš nízké.	Zvyšte ARC FORCE.	
10	Nestabilní oblouk	Nepříznivý vliv průvanu	Použijte zástěnu.	
		Excentrická elektroda	Změňte úhle uchycení elektroda	
			Vyměňte elektrodu	
		Vliv magnetismu	Nahněte elektrodu proti směru magnetického vlivu.	
Změňte pozici zemnicího kabelu nebo přidejte zemnicí kabel na opačnou stranu svařence.				
11	LED ALARM svítí	Přehřátí	Stroj zatížen příliš	Počkejte, až se stroj vychladí
		Ochrana přepětí	Nestandardní proud na hlavním obvodu.	Otestujte a opravte hlavní obvod PCB poř.č42

## TROUBLESHOOTING

S/N	Troubles	Reasons	Solutions
1	Turn on the power source, and fan works, but the power light is not on.	The power light damaged or connection is not good	Test and repair the inside circuit of power light s/n 4
		Power PCB failures	Repair or change power PCB s/n 42
2	Turn on the power source, and the power light is on, but fan doesn't work	There is something in the fan	Clear out
		The fan motor damaged	Change fan motor
3	Turn on the power source, and the power light is not on, and fan doesn't work	No input voltage	Check whether there is input voltage

		Overvoltage (Input voltage is too much or not)	Check input voltage	
4	No no-load voltage output	There is trouble inside the machine	Check the power switch	
5	No current output in the welding	Welding cable is not connected with the two output of the welder.	Connect the welding cable to the welder's output	
		Welding cable is broken	Wrap, repair or change the welding cable	
		Earth cable is not connected or loosen	Check the earth clamp	
6	Not easy to start arc in the welding, or easy to cause sticking	The plug loosen or connect not well	Check and tighten the plug	
		Oil or dust covered the workpiece	Check and clear out	
		MMA/TIG welding selection is wrong	Selecting the MMA welding	
7	The arc is not stable in the welding process	The arc force is too small	Increase the arc force	
8	The welding current can not be adjusted	The welding current potentiometer in the front panel connection not so good or damaged	Repair or change the potentiometer	
9	The penetration of molten pool is not enough(MMA)	The welding current adjusted too low	Increase the welding current	
		The arc force adjusted too small	Increase the arc force	
10	Arc blow	Airflow disturbance	Use the shelter from airflow	
		The electrode eccentricity	Adjust the electrode angle	
			Change the electrode	
		Magnetic effect	Incline the electrode to the opposite way of the magnetic blow	
Change the position of earth clamp or add earth cable in the two side of workpiece				
11	The alarm light is on	Over heat protection	Over welding current	Induce the welding current output
			Working time too long	Induce the duty cycle (interval work)
		Over current protection	Unusual current in the main circuit	Test and repair the main circuit and drive PCB s/n 42

**5. KONTROLA SILOVÉ PCB**

**CHECKING THE POWER PCB**

Obrázek 1



Zkontrolujte , že kabely které jdou z PCB výstupní filtr 0067 k PCB řídicí jsou spojené a neporušené



Obrázek 2

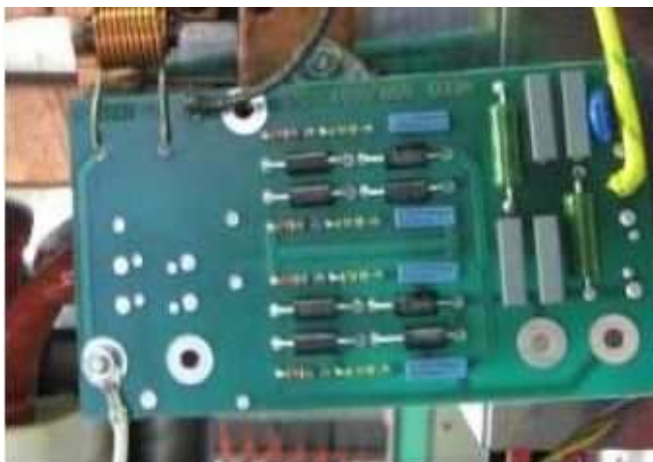

Před kontrolou výstupních usměrňovačů odpojte vývody k PCB RC filtr (černé a hnědý drát) a změřte podle následující tabulky

červený	černý	hodnota
DOWN	LEFT	OL
DOWN	RIGHT	0,3
LEFT	DOWN	0,3
RIGHT	DOWN	OL
LEFT	UP	0,3
RIGHT	UP	OL
UP	LEFT	OL
UP	RIGHT	0,3

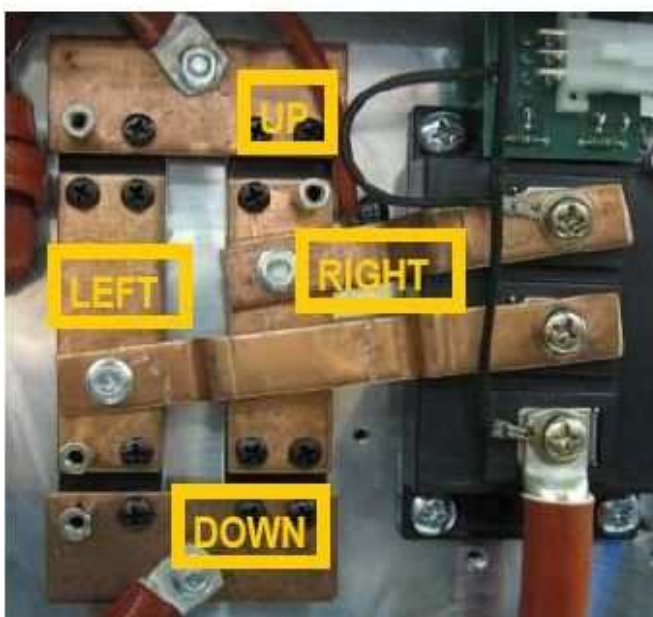

Nakonec zkontrolujeme osm transilů na PCB RC filtr. V obou směrech musí vykázat přerušný obvod



Obrázek 3

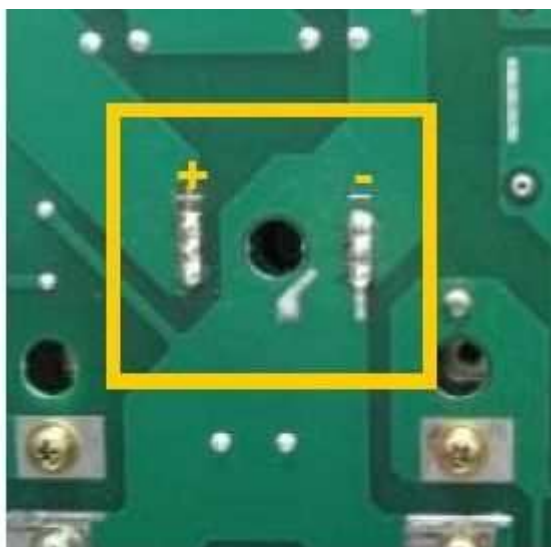

Vstupní usměrňovač na silové desce

Pro kontrolu můstku změřte tento mezi přívodními vodiči na PCB 0068 a +- kontakty vstupního usměrňovače podle tabulky

Červený	Černý	hodnota
AC	+	0.4 / 0,5
AC	-	OL
+	AC	OL
-	AC	0.4 / 0,5

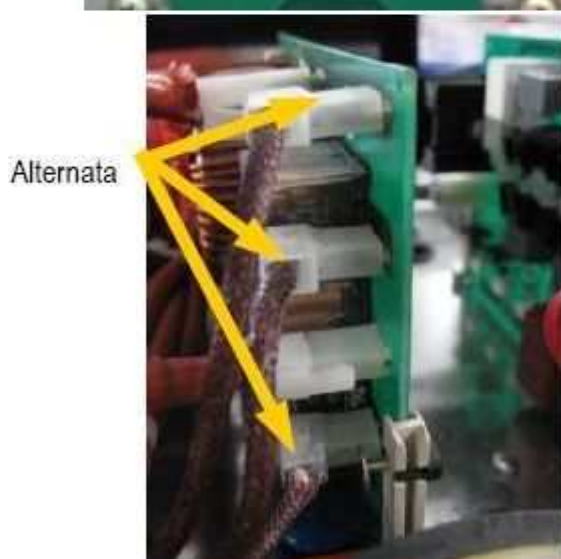

Obrázek 4

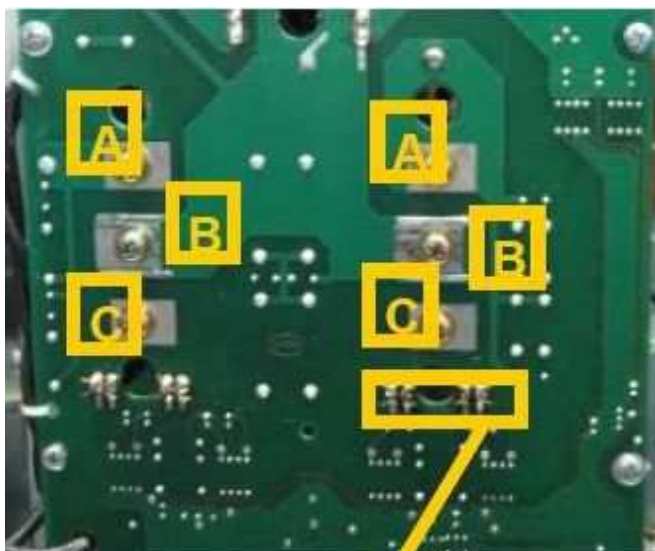

Pro kontrolu IGBT modulů změřte tyto podle následující tabulky testerem diod

červený	černý	hodnota
A	C	0,4
C	A	OL
A	B	OL
C	B	OL
B	A	0,4
B	C	0,8

Hodnoty jsou orientační. Naměříte-li zkrat, nebo rozpojený obvod (OL), je nutné PCB vyměnit

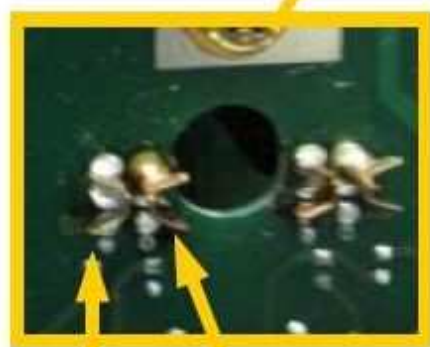

červený    černý

Dále použijte tester pro změření nožiček na zvětšenině, hodnoty musí být vždy OL

Obrázek 5

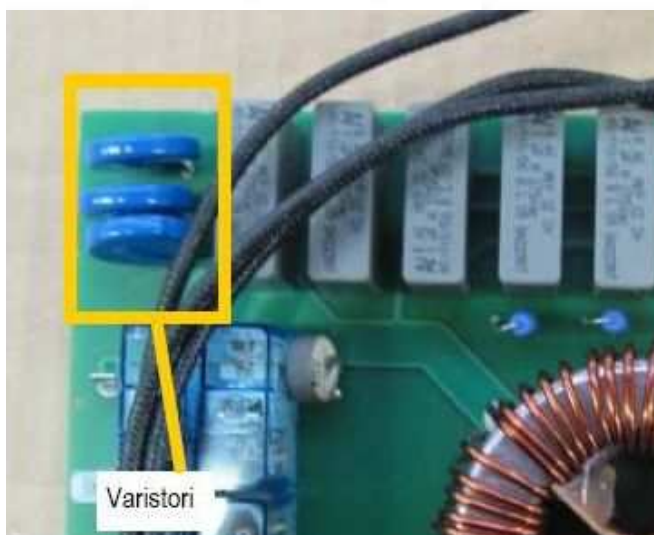

Varistory jsou blízko vstupu napájecího napětí na silovou PCB. Toto zařízení slouží k ochraně PCB před vstupním přepětím. Při přepětí "exploduje" a zkratuje vstup. Je-li rozsah zkratu velmi vysoký, obvod se přeruší





Pomocný transformátor připojen přes 10 pinový konektor s PCB silovou. Ujistěte se, že výstupy z transformátoru jsou správně nainstalovány tak, jak je vidět na obrázku

Cable data

Obrázek 6

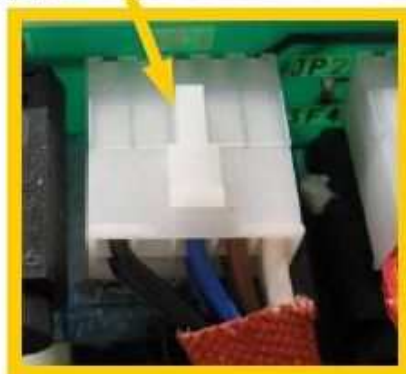
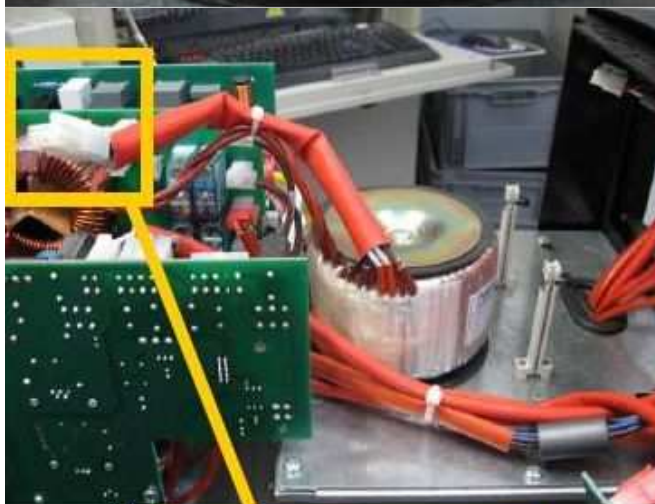



Obrázek 7

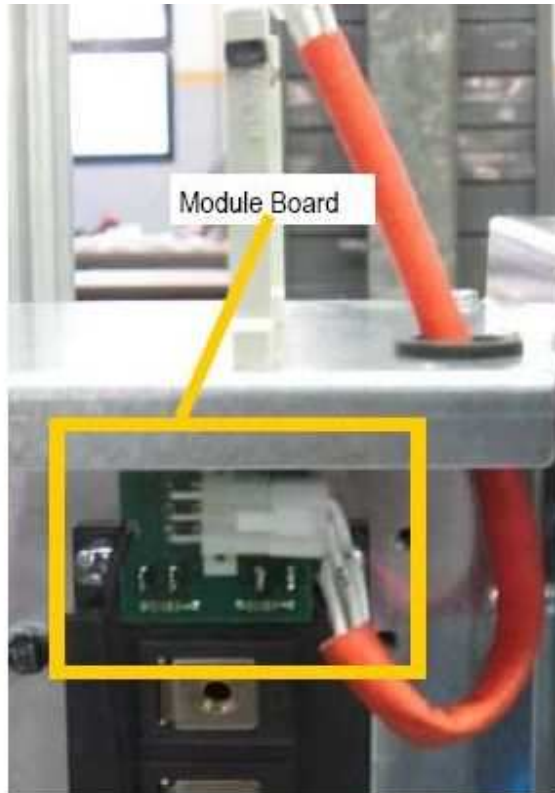

Zkontrolujte propojovací dráty mezi PCB inverzní a modulem podle obrázku

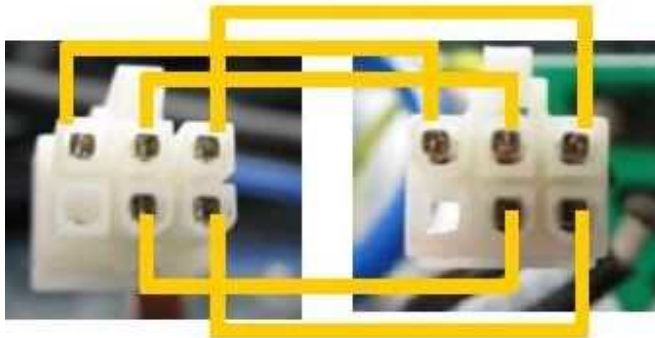

Obrázek 8

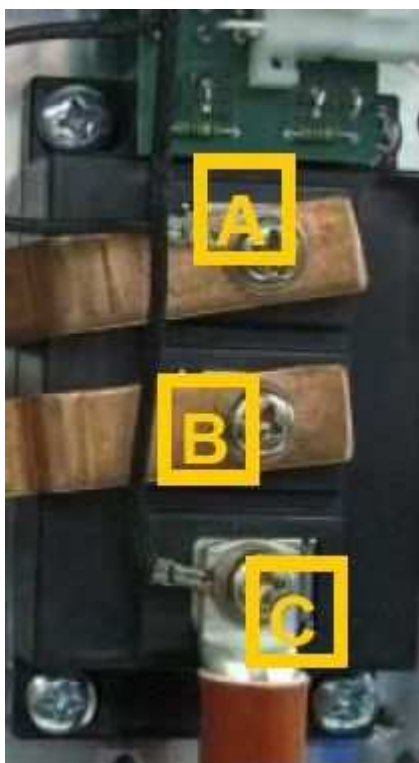

Pro kontrolu střídače podle následující tabulky

červený	černý	hodnota
B	A	0,6
B	C	0,3
A	B	OL
C	B	OL
C	A	0,3
A	C	OL

Naměříme-li jiné hodnoty, panel se musí vyměnit

Obrázek 9

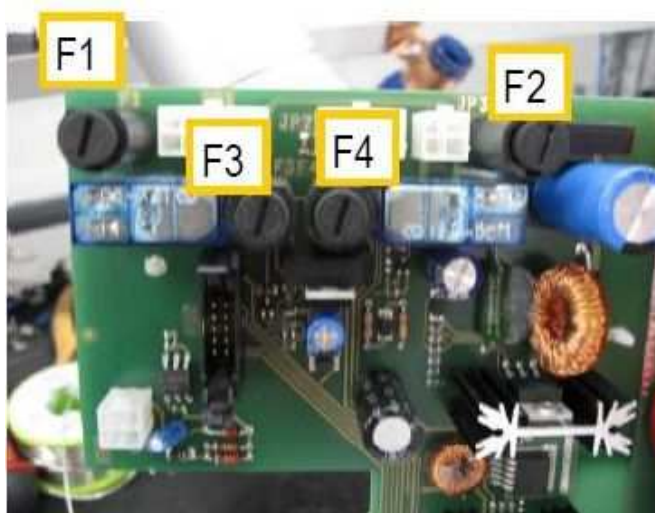

Pojistky:

- F1: 2.5 A;
- F2: 2.5 A;
- F3: 250 mA;
- F4: 1A.

Obrázek 10



Digitální multimetr. "OL" označuje přerušný obvod

**CAUTION!**

Before carrying out any work on the machine make sure it is off and the plug has been disconnected.



PROBLEM	CASE	SOLUTION
The machine does not switch on.	<ul style="list-style-type: none"> <li>- Electrical power does not reach the machine.</li> <li>- Voltage reaches the machine switch but there is no voltage after the contacts.</li> <li>- There is voltage after the disconnecting switch but the machine does not go on.</li> </ul>	<ul style="list-style-type: none"> <li>• Make sure the line switches are closed, the protection devices (fuses) have not been enabled and that the power supply cable is intact.</li> <li>• Switch the machine off and disconnect the plug. Make sure that when the switch is closed, there is continuity between the contact input and output and the varistors are not broken. (picture 5). If they are damaged the line filter board 0068 must be replaced (picture 5). Otherwise check the power board.</li> <li>• Switch the machine off and disconnect the plug, check that the Power Transformer cable is connected to the Power Board (picture 6).</li> </ul>
The protection devices of the line set off when the switch is activated and the machine does not go on.	<ul style="list-style-type: none"> <li>- Damaged power supply cable with short-circuited wires.</li> <li>- Inverter is damaged.</li> </ul>	<ul style="list-style-type: none"> <li>• Switch off the machine and disconnect the plug. Make sure that there are no short circuits between the poles of the plug caused by a damaged power supply cable.</li> <li>• Switch off the machine, disconnect the plug and check: <ul style="list-style-type: none"> <li>- varistors (picture 5);</li> <li>- inverter (picture 4);</li> <li>- Input bridge rectifier (picture 3);</li> </ul> </li> </ul>

PROBLEM	CASE	SOLUTION
The front panel does not switch on.	<ul style="list-style-type: none"> <li>- The flat cable that connects the front panel to the power board is not correctly inserted.</li> <li>- The Fuse F4 is damaged.</li> </ul>	<ul style="list-style-type: none"> <li>• Switch off the machine and disconnect the plug. Make sure the flat cable that connects the front panel to the power board is inserted correctly. If correctly inserted, replace the front panel</li> <li>• If the front panel doesn't work there's probably a feeding problem. In this case the fuse F4 must be replaced (picture 10). If the problem remains, try to replace the Power Board the Toroidal Transformers. Otherwise the front panel can be damaged, so it must be replaced.</li> </ul>
The Machine works and weld but the fan doesn't work (The thermal cycles of the machine are too short).	<ul style="list-style-type: none"> <li>- The cable that connects the Power Board to the Fan is not correctly inserted.</li> <li>- The Fuse F2 is damaged.</li> </ul>	<ul style="list-style-type: none"> <li>• Connect the cable or eventually replace it.</li> <li>• Replace the Fuse F2 (picture 10) and if the problem remains, replace the Power Board or the Fan. Otherwise if the fuse is ok but the fan doesn't work, the front panel must be replaced.</li> </ul>
The output voltage in MMA/TIG is about 11V and the Machine doesn't weld.	<ul style="list-style-type: none"> <li>- There's no contact between the fixed socket and the output filter board 0067.</li> <li>- The wires that connect the output filter board 0067 to the front panel (0045/0016) are not correctly connected or damaged.</li> <li>- The cable that connects the inversion board 0066 to the module board 0017 is not correctly connected or is damaged.</li> <li>- The cable that connects the front panel 0045/0016 to the inversion board is not correctly inserted or is damaged.</li> <li>- The front panel is damaged.</li> <li>- The power board and/or the inversion board are damaged.</li> </ul>	<ul style="list-style-type: none"> <li>• Switch off the machine and disconnect the plug: <ul style="list-style-type: none"> <li>- Replace the output filter board 0067.</li> </ul> </li> <li>- Connect the cables or if they are damaged replace them (picture 1).</li> <li>- Connect the inversion board cable to the module board and whether it's damaged, replace it (picture 7).</li> <li>- Connect the cable to the inversion board and whether it's damaged, replace it.</li> <li>- Replace the damaged boards.</li> </ul>
The output voltage in each procedure is about 10V and enabling of the thermal protection device.	<p>Wait a few minutes keeping the machine on to favour cooling of the inverter. If the machine continues running with the protection devices on, switch the machine off and disconnect the plug. Remove the hood and make sure:</p> <ul style="list-style-type: none"> <li>- the temperature of the heat sink tool is less than 40°C;</li> <li>- If it is less than 40°C, check whether the thermal protective device contacts are normally closed.</li> </ul>	<ul style="list-style-type: none"> <li>- If one of the protection devices is always opened it is defective, it must be accordingly replaced.</li> <li>- If it is closed, make sure the two terminals are well inserted in the connector.</li> <li>- Power board feed problems, it must be accordingly replaced.</li> </ul>

PROBLEM	CASE	SOLUTION
The output voltage in MMA/TIG is zero and the welding procedure is blocked in MMA.	<ul style="list-style-type: none"> <li>- Transils on the snubber board 0065 are damaged.</li> <li>- The Inversion Module is damaged.</li> <li>- ISOTOP diodes are in short circuit.</li> <li>- The inductive value of the Power Transformer is null.</li> </ul>	<p>Switch off the machine and disconnect the plug. Remove the snubber board 0065 ( above the ISOTOP diodes):</p> <ul style="list-style-type: none"> <li>• check with a diode tester the status of the transils on the snubber board. If it's damaged, it must be replaced (picture 2);</li> <li>• Check with a diode tester the status of the inversion module. If it's damaged, it must be replaced (picture 8);</li> <li>• check with a diode tester the status of the diodes. If they are damaged, they must be replaced (picture 2);</li> <li>• Otherwise the Power Transformer could be damaged, then it must be replaced.</li> </ul>
The welding is non optimal.	<ul style="list-style-type: none"> <li>- Spattering occurs during MMA welding.</li> <li>- The arc goes out during AC welding.</li> </ul>	<ul style="list-style-type: none"> <li>• Make sure welding polarity is correct, the earth clamp is fixed correctly and check the hot-start and arc-force values that have to be decreased if they are too high.</li> <li>• The inversion board 0066 or the front panel must be replaced.</li> </ul>
When welding the protection devices of the line set off.	Make sure the welding current does not require greater power than the one supplied by the line.	Decrease the welding current.
The remote control is damaged.	<ul style="list-style-type: none"> <li>• Make sure the wiring which goes to the 0016/0045 front panel board is connected.</li> <li>• The front panel could be damaged.</li> <li>• The fuse F2 is damaged.</li> </ul>	<ul style="list-style-type: none"> <li>- Insert the wires into the connectors correctly and insert the connectors into their housings. Should this not be sufficient, replace the front panel board</li> <li>- Replace F2 fuse (picture 10) and should it continue to blow, replace the power board and/or the auxiliary transformer.</li> </ul>

PROBLEM	CASE	SOLUTION
The cooling device doesn't work	<ul style="list-style-type: none"> <li>- The fuse F1 could be damaged.</li> <li>- The wiring which connects power board 0036 to the 0068 input filter board is disconnected or damaged. The wiring which goes from the 0069 input filter board to the on/off panel is disconnected</li> <li>- The front panel could be damaged..</li> <li>- The line filter board 0068 must be replaced.</li> </ul>	<ul style="list-style-type: none"> <li>• The fuse F1 must be replace (picture 10).</li> <li>• Connect the cables or, if damaged, replaced them.</li>   <li>• The damaged boards must be replace.</li> </ul>
The machine does not strike in HF mode.	<ul style="list-style-type: none"> <li>- The front panel could be damaged.</li> <li>- The HF board could be damaged.</li> <li>- HF board cable could be damaged or disconnected.</li> </ul>	<ul style="list-style-type: none"> <li>• The front panel must be replaced</li> <li>• The HF board must be replaced.</li> <li>• Connect the cables or, if damaged, replace them.</li> </ul>

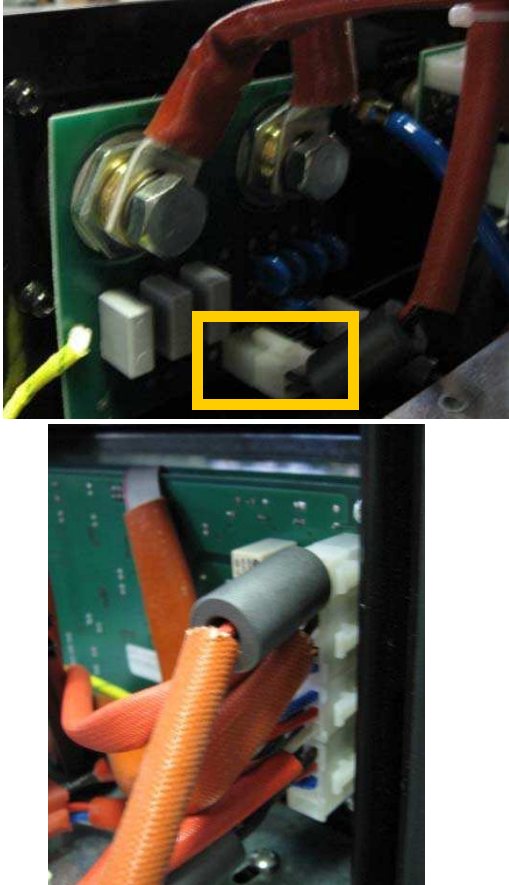
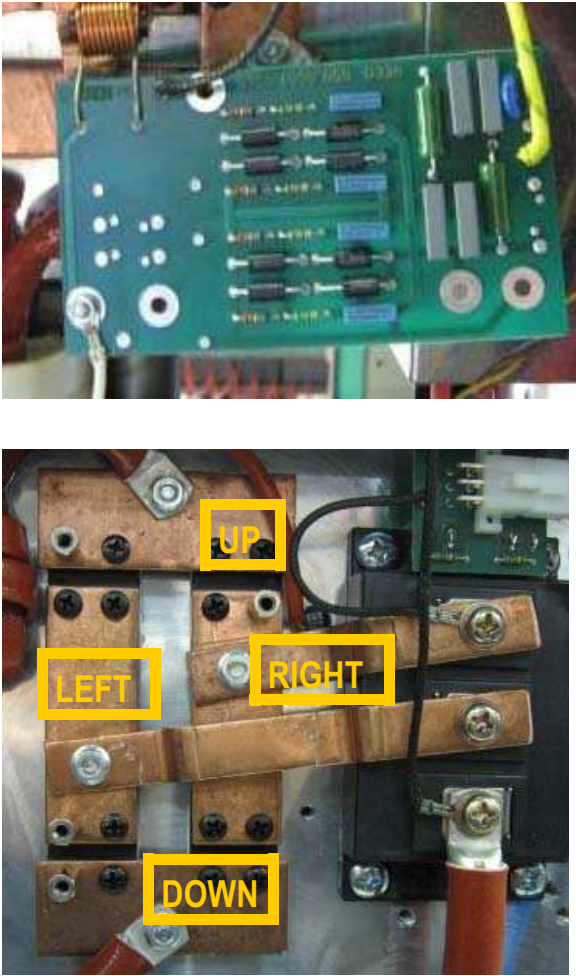

		EXPLANATION																																													
<p>PICTURE 1</p>		<p>Check that the cables that connect the output filter board 0067 to the front panel are correctly inserted.</p>																																													
<p>PICTURE 2</p>		<p>To check diodes remove the snubber board and carry out the following measures with a diode tester:</p> <table border="1" data-bbox="842 1220 1501 1691"> <thead> <tr> <th>Copper bar</th> <th>Probe</th> <th>Copper bar</th> <th>Probe</th> <th>Measure</th> </tr> </thead> <tbody> <tr> <td>DOWN</td> <td>Red</td> <td>LEFT</td> <td>Black</td> <td>“OL”</td> </tr> <tr> <td>DOWN</td> <td>Red</td> <td>RIGHT</td> <td>Black</td> <td>0.3</td> </tr> <tr> <td>DOWN</td> <td>Black</td> <td>LEFT</td> <td>Red</td> <td>0.3</td> </tr> <tr> <td>DOWN</td> <td>Black</td> <td>RIGHT</td> <td>Red</td> <td>“OL”</td> </tr> <tr> <td>UP</td> <td>Black</td> <td>LEFT</td> <td>Red</td> <td>0.3</td> </tr> <tr> <td>UP</td> <td>Black</td> <td>RIGHT</td> <td>Red</td> <td>“OL”</td> </tr> <tr> <td>UP</td> <td>Red</td> <td>LEFT</td> <td>Black</td> <td>“OL”</td> </tr> <tr> <td>UP</td> <td>Red</td> <td>RIGHT</td> <td>Black</td> <td>0.3</td> </tr> </tbody> </table> <p>At the ends of the two transils (see below) positioned on the snubber board, “OL” must always be measured.</p> 	Copper bar	Probe	Copper bar	Probe	Measure	DOWN	Red	LEFT	Black	“OL”	DOWN	Red	RIGHT	Black	0.3	DOWN	Black	LEFT	Red	0.3	DOWN	Black	RIGHT	Red	“OL”	UP	Black	LEFT	Red	0.3	UP	Black	RIGHT	Red	“OL”	UP	Red	LEFT	Black	“OL”	UP	Red	RIGHT	Black	0.3
Copper bar	Probe	Copper bar	Probe	Measure																																											
DOWN	Red	LEFT	Black	“OL”																																											
DOWN	Red	RIGHT	Black	0.3																																											
DOWN	Black	LEFT	Red	0.3																																											
DOWN	Black	RIGHT	Red	“OL”																																											
UP	Black	LEFT	Red	0.3																																											
UP	Black	RIGHT	Red	“OL”																																											
UP	Red	LEFT	Black	“OL”																																											
UP	Red	RIGHT	Black	0.3																																											



PICTURE 3

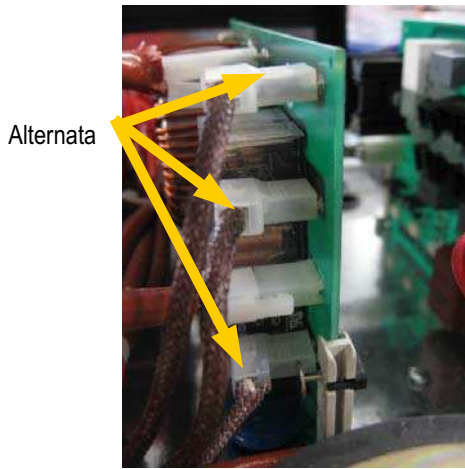
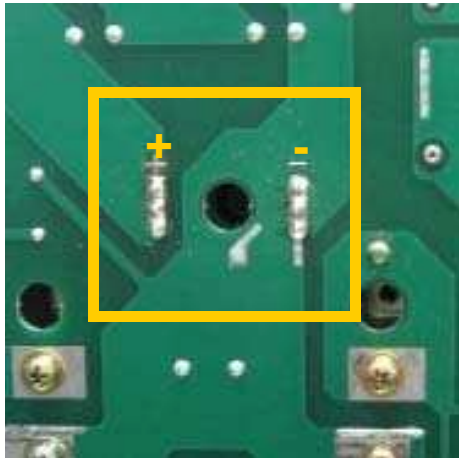

**EXPLANATION**

Input bridge rectifier on the Power Board 0035.

To check the Input bridge rectifier, carry out the following measurements with a diode tester:

Faston	Probe	Faston	Probe	Measure
+	Red	-	Black	"OL"
-	Red	+	Black	0.7 ca.

Should there be a short circuit on one of these measurements, the input bridge rectifier must be replaced.

Subsequently carry out the following measurements between the diode bridge and the alternate wirings situated on board 0068 as well:

Red Probe	Black Probe	Measure
+	Alternata	"OL"
-	Alternata	0,4 / 0,5
Alternata	+	0,4 / 0,5
Alternata	-	"OL"

PICTURE 4

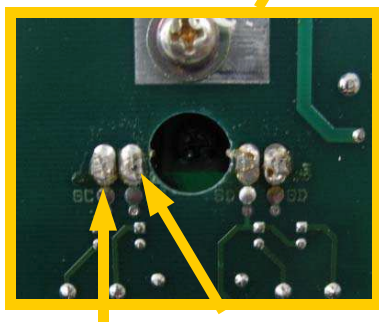
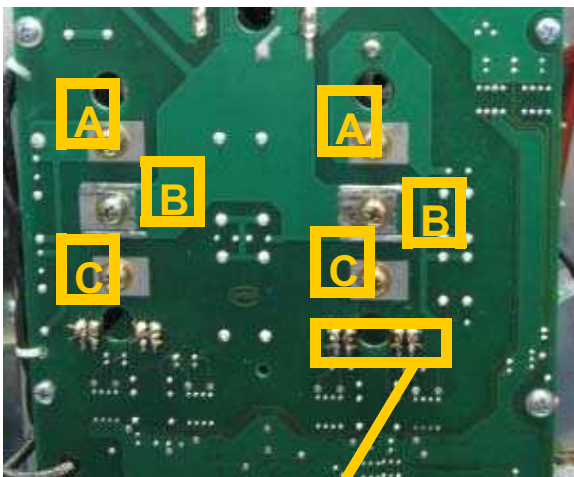

Red Black



To check the inverter, carry out the following measurements with a diode tester:

Red Probe	Black Probe	Measure
A	C	0.4
C	A	"OL"
A	B	"OL"
C	B	"OL"
B	A	0.4
B	C	0.8

Should there be a short-circuit on one of these measurements or an "OL" instead of a numeric value, the power board must be replaced.

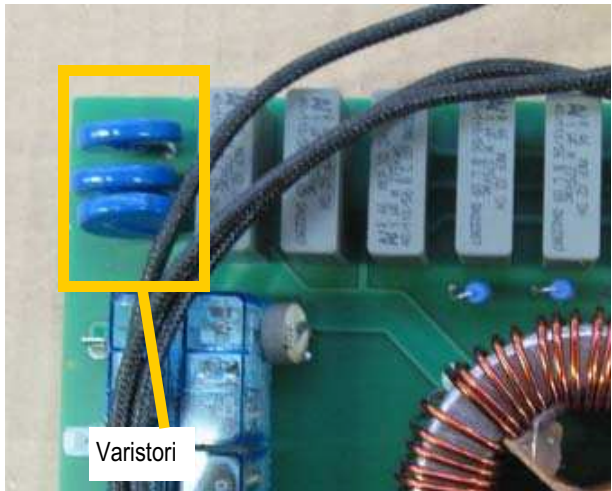
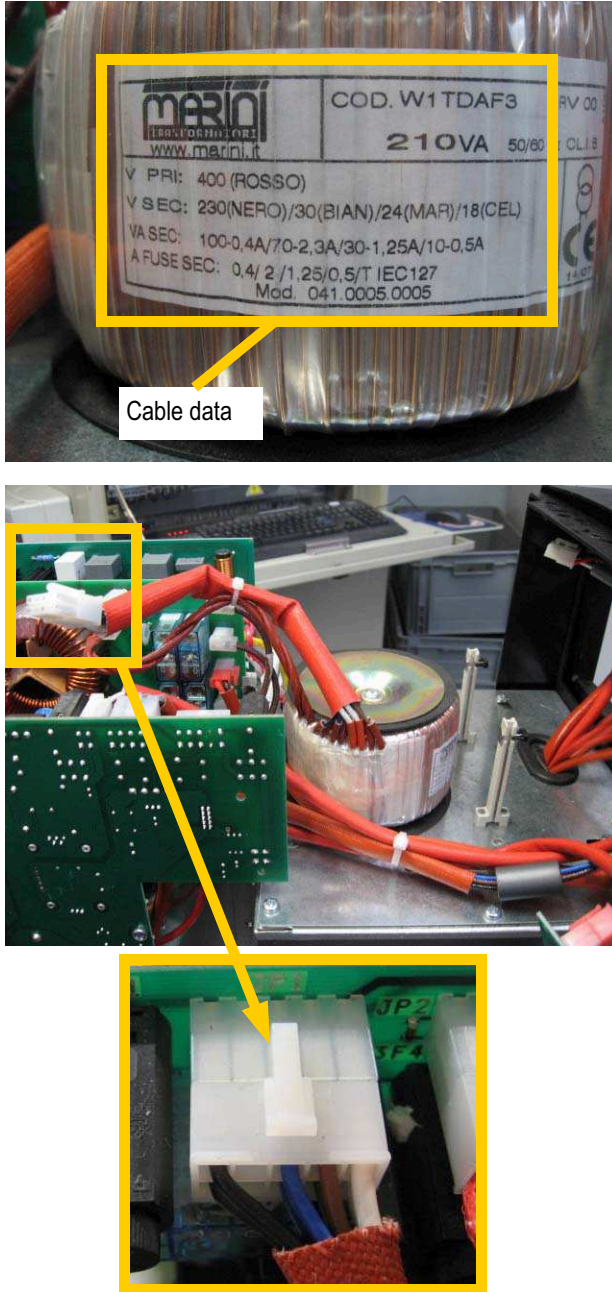
Use the tester to measure the pins indicated in the enlarged picture – the values obtained must always be "OL" (on all four pairs of pins).

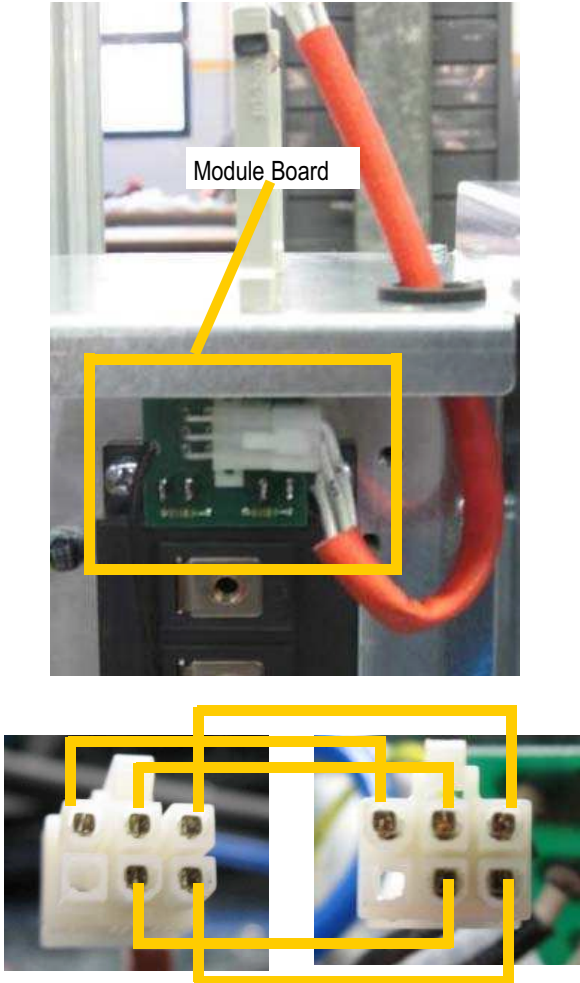
		EXPLANATION
<p style="writing-mode: vertical-rl; transform: rotate(180deg);"><b>PICTURE 5</b></p>	 <p style="text-align: center;">Varistori</p>	<p>The varistors are three blue discs near the ground wire of the power board. These devices are for protecting the board from input overvoltage. When there is overvoltage they “explode” causing a short circuit most of the times. If the extent of the short circuit is very high they become an open circuit.</p>
<p style="writing-mode: vertical-rl; transform: rotate(180deg);"><b>PICTURE 6</b></p>	 <p style="text-align: center;">Cable data</p>	<p>The auxiliary transformer is connected by means of a 10-way connector to the power board. Make sure the outputs of the transformer are connected correctly and the wirings, whose data are indicated on the auxiliary transformer, are inserted into the connector in the following way and as indicated in the picture.</p> <ul style="list-style-type: none"> <li>- pin 1/6: white wires;</li> <li>- pin 2/7: brown wires;</li> <li>- pin 3/8: blue wires;</li> <li>- pin 5/10: black wires.</li> </ul>

		<b>SPIEGAZIONE</b>																																			
<b>PICTURE 7</b>		<p>Make sure that the wiring that connects the module control board situated on the module to the 0066 inversion board is intact and connected well. Make sure that the wiring of the module inversion control has all wires inserted well in their respective pins as shown in the picture.</p>																																			
<b>PICTURE 8</b>		<p>If the no-load voltage is null that means the module may have a short circuit. To check the inversion module, remove the snubber board and all the connectors on the 0066 board. After that carry out the following measurements with a diode tester:</p> <table border="1" data-bbox="842 1592 1501 1962"> <thead> <tr> <th>Copper bar</th> <th>Probe</th> <th>Copper bar</th> <th>Probe</th> <th>Measure</th> </tr> </thead> <tbody> <tr> <td>B</td> <td>Rosso</td> <td>A</td> <td>Nero</td> <td>0.6</td> </tr> <tr> <td>B</td> <td>Rosso</td> <td>C</td> <td>Nero</td> <td>0.3</td> </tr> <tr> <td>B</td> <td>Nero</td> <td>A</td> <td>Rosso</td> <td>"OL"</td> </tr> <tr> <td>B</td> <td>Nero</td> <td>C</td> <td>Rosso</td> <td>"OL"</td> </tr> <tr> <td>A</td> <td>Nero</td> <td>C</td> <td>Rosso</td> <td>0.3</td> </tr> <tr> <td>A</td> <td>Rosso</td> <td>C</td> <td>Nero</td> <td>"OL"</td> </tr> </tbody> </table> <p>If the values are not correct, the inversion module must be replaced.</p>	Copper bar	Probe	Copper bar	Probe	Measure	B	Rosso	A	Nero	0.6	B	Rosso	C	Nero	0.3	B	Nero	A	Rosso	"OL"	B	Nero	C	Rosso	"OL"	A	Nero	C	Rosso	0.3	A	Rosso	C	Nero	"OL"
Copper bar	Probe	Copper bar	Probe	Measure																																	
B	Rosso	A	Nero	0.6																																	
B	Rosso	C	Nero	0.3																																	
B	Nero	A	Rosso	"OL"																																	
B	Nero	C	Rosso	"OL"																																	
A	Nero	C	Rosso	0.3																																	
A	Rosso	C	Nero	"OL"																																	

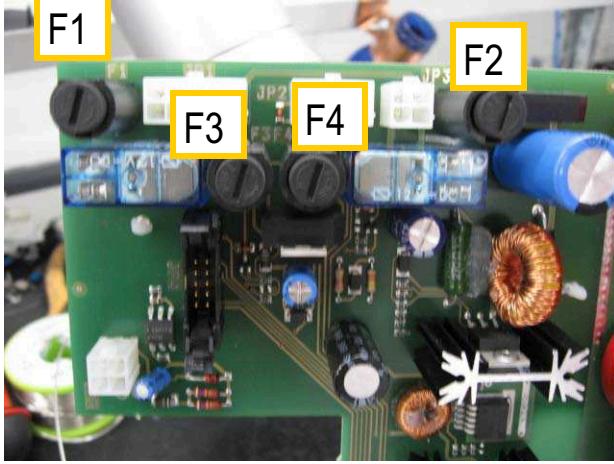

		EXPLANATION
<p style="writing-mode: vertical-rl; transform: rotate(180deg);">PICTURE 9</p>		<p>Tester or digital millimetre. "OL" means Open Loop.</p>
<p style="writing-mode: vertical-rl; transform: rotate(180deg);">PICTURE 10</p>		<p>Fuses:</p> <ul style="list-style-type: none"> <li>- F1: 2.5 A;</li> <li>- F2: 2.5 A;</li> <li>- F3: 250 mA;</li> <li>- F4: 1A.</li> </ul>

**MG055-2 SERVISNÍ MANUÁL / SERVICE MANUAL ALFIN 281 AC/DC**

Vypracoval: Worked out:	DJ 19/4/2010	Přezkoumal: Inspected:	DJ 19/4/2010	Schválil: Approved:	VS 19/4/2010
----------------------------	--------------	---------------------------	--------------	------------------------	--------------