

■ RAIL BULL | TRACK WELDING CARRIAGE WITH OSCILLATOR

The Rail Bull is a track welding carriage designed to produce butt and fillet welds with or without oscillation.

The carriage can work in PA (flat), PB (horizontal vertical), PC (horizontal), PD (overhead horizontal-vertical), PE (overhead), PF (vertical-up) and PG (vertical-down) welding positions.



■ Applications:

- Trailer manufacturing
- Truck tanks
- Oil tanks
- Water storage tanks
- Pressure vessels
- Vessel overlay/Hard facing
- Bridge girders
- Structural steel
- Structural towers
- Panel welding
- Transformers
- Shipyards
- Any application demanding long, continuous welds

Rail Bull moves along either rigid or semi-flexible track on both ferromagnetic and non-ferromagnetic materials thanks to rack and pinion drive and tracks fixed to flat or curved surfaces by means of various magnetic or vacuum units.

The minimum curvature radius required for semi-flexible track is 5 m (16 ft).



Continuous welding



Horizontal speed 0-120 cm/min



Vertical speed 0-110 cm/min



Linear oscillation with trapezoid, triangle and straight line paths

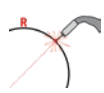

Min. path convex radius 5000 mm



Min. path concave radius 5000 mm

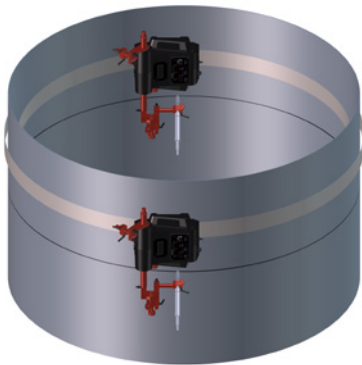
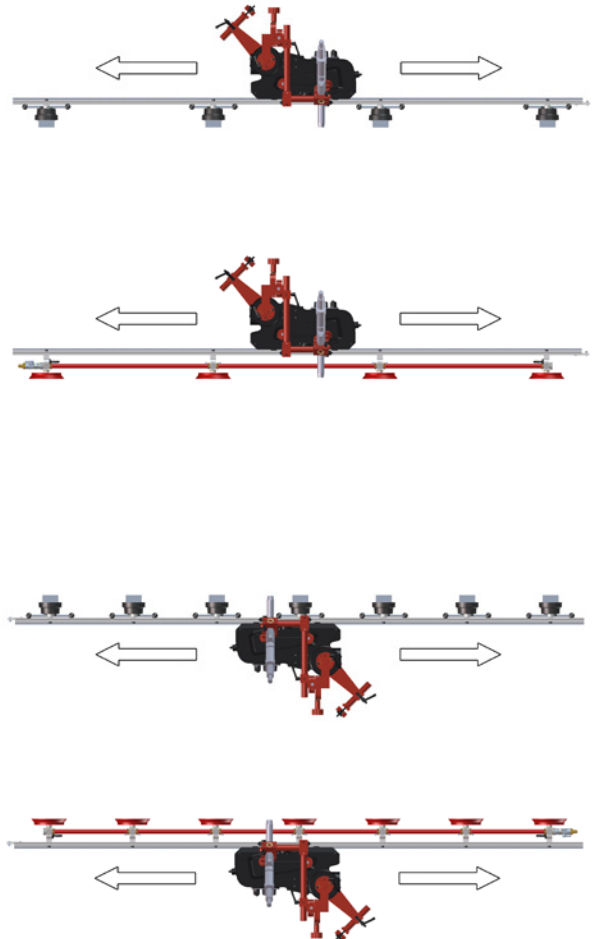
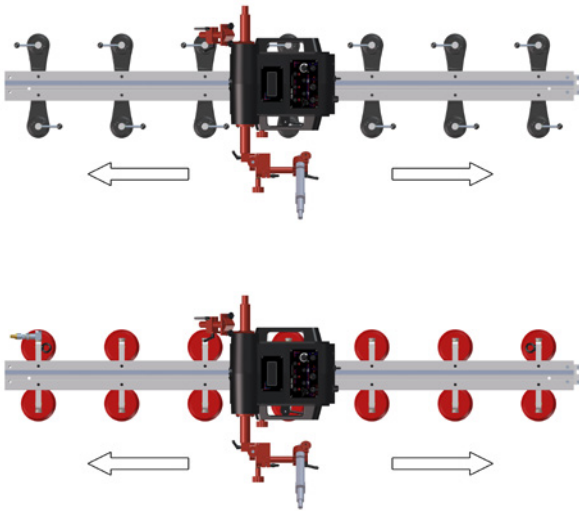

1. Power switch
2. Control panel
3. Torch holder with clamp
4. Oscillator arm
5. Display
6. Cable anchor
7. Drive clutch knob
8. Mounting lever
9. Carrying handle
10. Arc ignition socket

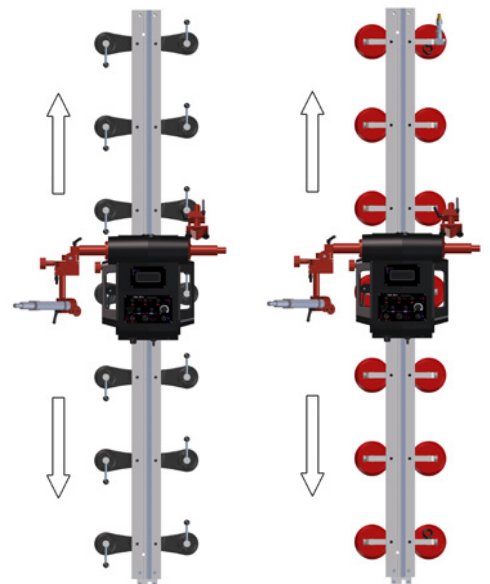
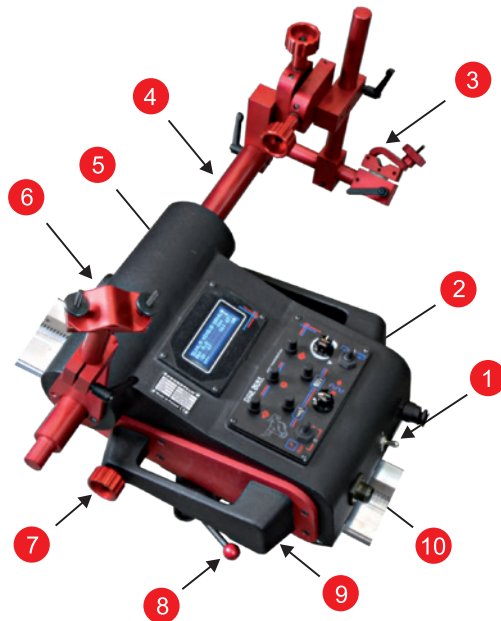

Primary features and benefits:

- Compact, lightweight design with durable aluminum cast housing
- Convenient Power Supply 115–230 V, 50–60 Hz or 42 V, 50–60 Hz
- Quick clamping torch holder mechanism for different types of MIG/MAG torches with diameters of 16–22 mm (0.63–0.87”); up to 35 mm (1.38”) option
- Precise torch adjustment with screw drive cross slide
- Ready to work in both vertical and horizontal positions
- Multifunctional LED display (process parameters & warnings)
- Consistent heat input reduces distortion
- Reduce wasted filler metal - eliminates over welding
- Automatic arc on/off initiates welding and travel, simultaneously
- Closed-loop position control system based on electric motor with encoder – ensures increased accuracy of speed and positioning
- Improves working environment - removes operator from heat and fumes
- Linear torch oscillator to produce weave welds
- Menu in English (other languages on request)
- Rack and pinion drive
- Continuous welding
- Rigid rail track system

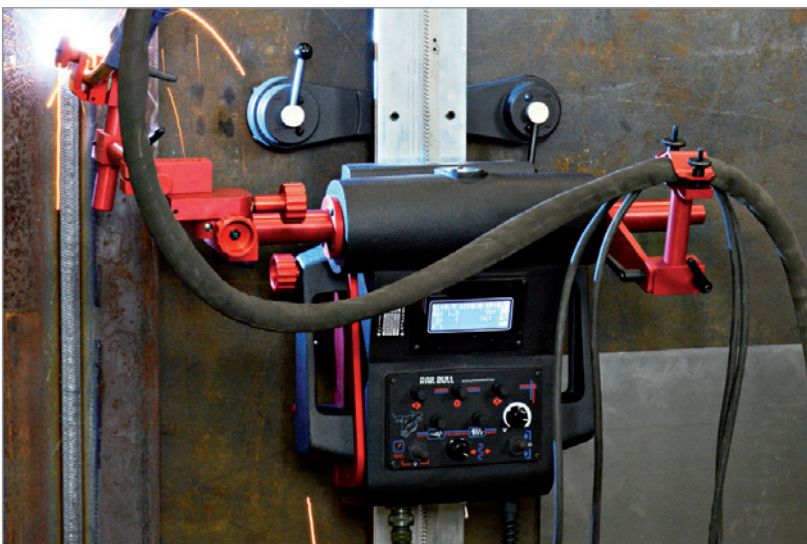
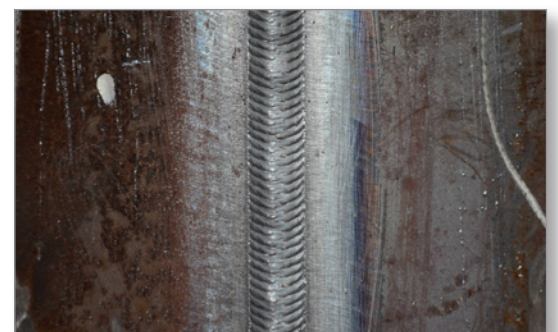

TECHNICAL SPECIFICATIONS RAIL BULL

Voltage	1~ 115–230 V, 50–60 Hz 42 V, 50–60 Hz
Power	100 W
Welding position (according to EN ISO 6947 and AWS/ASME)	PA / 1F / 1G PB / 2F PC / 2G PD / 4F PE / 4G PF / 3G PG / 3G
Torch diameter	16–22 mm (0.63–0.87"); up to 35 mm (1.38") option
Minimum radius of curved workpiece surface	5000 mm (16 ft)
Minimum workpiece thickness	5 mm (0.2")
Horizontal pulling force	350 N
Vertical pulling force	150 N
Cross slide adjustment range	0–35 mm (0–1.38") up-down, left-right
Horizontal speed	0–120 cm/min (0–47.2 in/min)
Vertical speed	0–110 cm/min (0–43.3 in/min)
Weight	20 kg (44 lbs)
Welding settings storage	1 (last used)
Oscillation type	linear (0 - 100 mm)
Oscillation (weaving) pattern	trapezoid, triangle, straight line
Oscillation width	0–50 mm (0–1.9")
Oscillation speed	0–1500 mm/min (0–59 in/min)
Oscillation delay time	0–5 s (at external and central points)
Product Code (115–230 V, 50–60 Hz, plug EU)	WOZ-0482-10-20-01-0
Product Code (115–230 V, 50–60 Hz, plug UK)	WOZ-0482-10-10-01-0
Product Code (42 V, 50–60 Hz)	WOZ-0624-10-04-00-0

Weld paths:

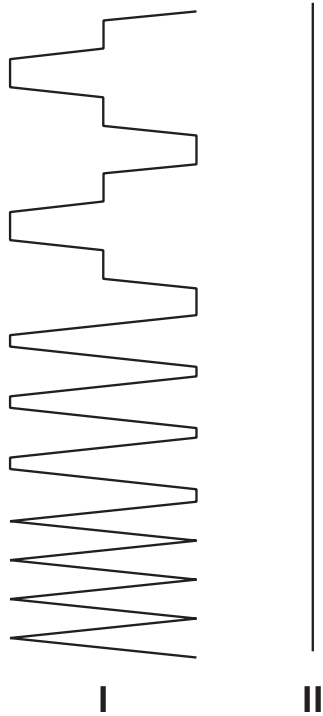

- I. Trapezoid The carriage travels continuously even during dwell mode. Weld path is determined by weave speed and dwell time at center and on sides of the weld path.
- II. Straight The carriage travels continuously while oscillation is switched-off.

Dimensions:

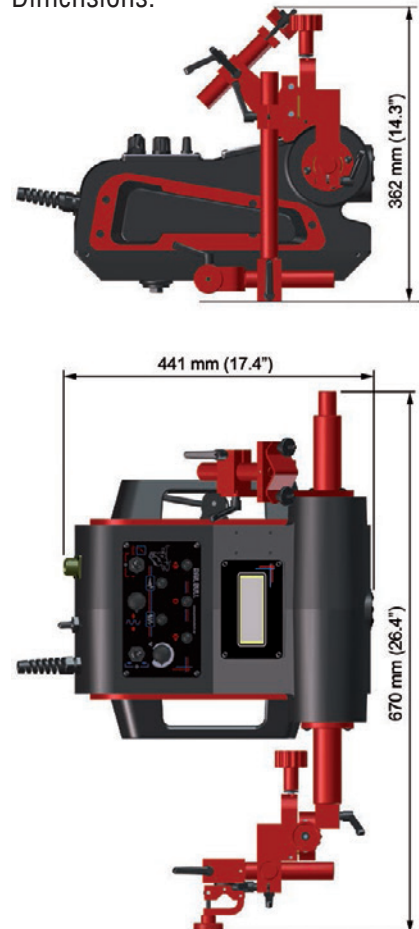

Standard accessories:



Power Cord 3m (10 ft)



KBL-0466-17-00-00-0
Dual Arc Ignition Cable of 6.5 m (21 ft)



UCW-0476-20-00-00-0 Torch Holder
Short Rod Clamp Assembly



UCW-0482-17-00-00-0
Cable Anchor



Rigid track length 2 m (6.5 ft)
PRW-0482-47-00-00-0



Bracket for magnetic unit
for rigid track
DYS-0482-21-00-00-0

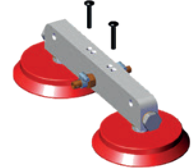

Vacuum modular unit
MST-0541-10-02-00-0



Magnetic narrow unit with hexagon
PDS-0582-10-00-02-0

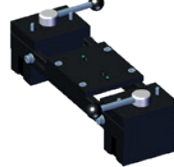

Magnetic spacing-adjustable unit
ZSP-0523-19-00-00-0

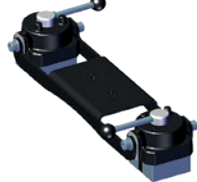

Magnetic pivoting unit
ZSP-0475-85-00-00-0

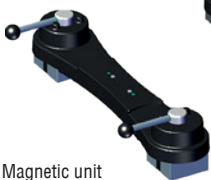

Magnetic unit
ZSP-0475-44-00-00-0



Heat-resistant
magnetic unit
ZSP-0475-44-00-00-1

Semi-flexible track length 2 m (6.5 ft)
Minimum 5 m (16 ft) curvature radius required
PRW-0482-15-05-00-0

Semi-flexible tracks can be custom rolled
permanently within the radius range from 1.5 m up to
5 m (5 ft up to 16 ft)

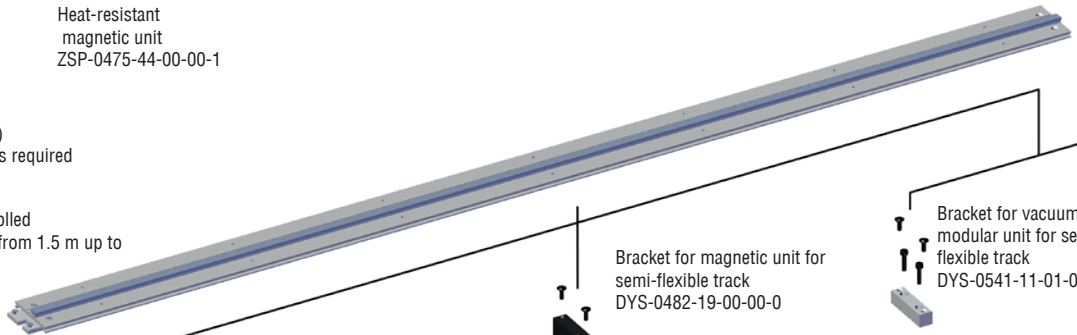

Bracket for
magnetic unit for
semi-flexible track
DYS-0482-19-00-00-0

Bracket for magnetic
narrow unit for semi-
flexible track
DYS-0582-10-00-02-0

Bracket for magnetic unit for
semi-flexible track
DYS-0482-19-00-00-0

Bracket for vacuum
modular unit for semi-
flexible track
DYS-0541-11-01-00-0



Aluminum track support
for semi-flexible track
WSP-0541-11-02-00-0

Vacuum modular unit
MST-0541-10-02-00-0

Magnetic spacing-adjustable unit
ZSP-0523-19-00-00-0

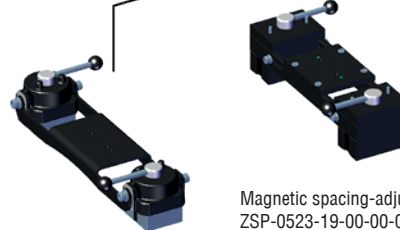

Magnetic pivoting unit
ZSP-0475-85-00-00-0



Steel track support for semi-
flexible track
WSP-0523-12-01-00-1



Magnetic narrow
unit with hexagon
PDS-0582-10-00-02-0

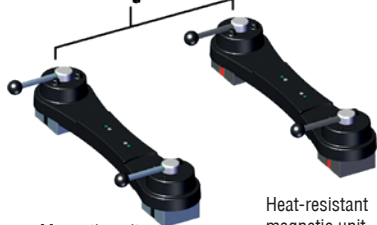

Magnetic unit
ZSP-0475-44-00-00-0

Heat-resistant
magnetic unit
ZSP-0475-44-00-00-1

Optional accessories for variety of applications:



PKT-0341-13-00-00-0
Gear Rack Adjustment Tool

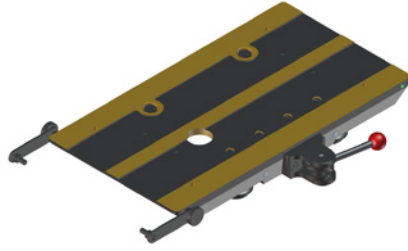

PEP-0482-18-00-00-0
Transport Attachment



ZCS-0476-06-01-00-0
16-22 mm Torch Clip



ZRZ-0466-19-00-00-0
22-35 mm Torch Clamp

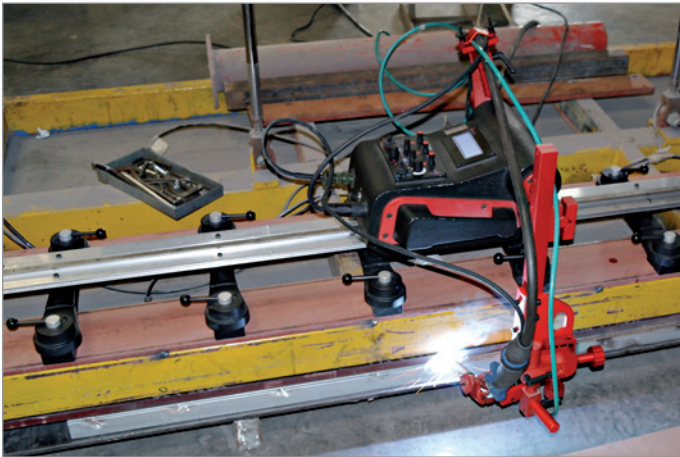

Rail Bull is suitable for work in both horizontal and vertical positions

The Rail Bull welding carriage is supplied in a metal box including:

- welding carriage
- metal box
- cross slide assembly
- short rod torch holder with clamp
- cable anchor
- power cord 3 m (10 ft)
- arc ignition cable of 6.5 m (21 ft)
- 3 mm hex wrench
- 4 mm hex wrench
- operator's manual

More information available at www.promotech.eu



Rail Bull features
User-friendly
control panel



American Welding Society
Supporting Company Member

Mitglied im DVS – Deutscher Verband für
Schweißen und verwandte Verfahren e. V.



All information is subject to change without notice. 1810



PROMOTECH Sp. z o.o.
ul. Elewatorska 23/1, 15-620 BIAŁYSTOK, POLAND
tel. (+48 85) 678 34 05, fax (+48 85) 662 78 77
marketing@promotech.eu www.promotech.eu

Find us on

Your local dealer:

