

WELDING INVERTER

**PERUN 160 T HF PULSE
PERUN 200 T HF PULSE**

OPERATING MANUAL

CONTENT:

1. INTRODUCTION	3
2. SAFETY PRECAUTIONS	4
3. OPERATING CONTROLS	5
4. TECHNICAL DATA	6
5. EQUIPMENT	7
6. OPERATOR CONTROLS	9
7. GETTING STARTED	12
8. TWO STROKE AND FOUR STROKE IN TIG MODE	17
9. JOBS	18
10. RESET	18
11. ROUTINE MAINTENANCE & INSPECTION	19
12. STATEMENT OF WARRANTY	19
13. DISPOSAL	20
14. WARRANTY LIST	21

1. INTRODUCTION

Dear consumer,
Company ALFA IN a.s. thanks you for buying our product and believe that you will be satisfied with our machine.

Welding inverters PERUN 160 – 200 T HF PULSE are designed for professional welding in TIG method with high-frequency arc ignition (HF) or LIFT ARC (with touch ignition) with pulse mode selection and in MMA method (coated electrode).

Welding inverters PERUN 160 – 200 T HF PULSE have these special functions for effective use: Pre gas and Post gas of protective gas, Up slope and Down slope, Start and Final current, HF ignition, 2T and 4T mode, Pulse mode, Bilevel and UP-DOWN control from the torch.

For MMA method are these machines equipped with functions HOT START, ARC FORCE and ANTISTICK.

In TIG method are machines equipped with function „fan as required“ (if it is not necessary to cool the machine, it automatically shuts down the fan).

Welding machine may be operated only by trained persons and only in the technical provisions. Company ALFA IN a.s. accept no responsibility for damage caused by improper use. Before commissioning please read carefully this manual.

The machine complies with the appropriate CE mark.
For maintenance and repairs, use only original spare parts. There is of course a complex of our services.

We reserve the law of adjustments and changes in case of printing errors, change of technical parameters, accessories etc. without previous notice. These changes may not be reflected in the manuals for use in paper or electronic form.



2. SAFETY PRECAUTIONS



PERSONAL PRECAUTION

1. For safety reasons, it is necessary to use welding gloves during welding. These gloves will protect you before intervention of electric current (open circuit voltage). It protects you against thermal radiation and splashing drops of hot metal too.
2. Wear sturdy isolated shoes. Do not wear open shoes, because drops of hot metal can cause burns.
3. Do not look into the welding arc without eye and face protection. Always use good quality welding helmet with intact protective filter.
4. The persons appearing in the vicinity of the welding must be informed of the danger and must be equipped with protective equipment.
5. During welding, especially in small spaces, it is necessary to ensure an adequate supply of fresh air, because during welding, harmful fumes arise.
6. In tanks of gas, oil, fuel, etc., (even empty ones) do not make welding, because there is a chance of explosion.
7. In areas with chance of explosion special provisions are applied.
8. Welding machines that are subjected to great exertion must comply with specific security requirements. These include the rail pressure of the vessel etc. These connections may only be carried out by competently trained welders with the necessary permissions.

SAFETY REGULATIONS

1. Before starting work with welding machine, it is necessary to get familiar with the provisions of the CSN 050601 and norm CSN 050630.
2. With a bottle of CO₂ or mixed gases should be handled according to the regulations for working with pressure vessels contained in CSN 07 83 05.
3. The welder must use protective equipment.
4. Before working on the electrical part, removing the cover or cleaning it is necessary to disconnect the device from the network.



3. OPERATING CONTROLS

1. Putting the machine into operation can be performed only by trained personnel and only within the technical provisions. The manufacturer is not liable for damages resulting from improper use or handling. For maintenance and repair, use only original spare parts from ALFA IN.
 2. Device complies with IEC 61000-3-12.
 3. The welding machine is tested according to the degree of protection IP 23S, which provides protection against the intrusion of solid bodies with a diameter greater than 12 mm and protection against ingress of water, falling on the machine in a vertical direction or max degree of 60°.
 4. Working ambient temperature between -10 and +40 °C.
 5. Relative humidity below 90% at +20 °C.
 6. Up to 3000 m altitude.
 7. The machine must be positioned so that cooling air can enter and leave through cooling vents with no problem. It is necessary to ensure that there are no mechanical equipment, especially metal particles (e.g. during grinding) drawn into the machine.
 8. It is necessary for welding machine to undergo a periodic inspection every 6/12 months by an authorized officer according to CSN 331500 and CSN 050630 – see Maintenance and service tests.
 9. All interventions in the el. equipment as well as repair (removal of the plug, fuse replacement) should be performed by an authorized person.
 10. With competent mains voltage and input must match the plug.
 11. PERUN 160-200 T HF PULSE is equipped with the function HOT START for perfect arc ignition, adjustable function ARC-FORCE which ensures stable arc and function ANTI STICK which prevents the electrode sticking to the weldment.
 12. Welding machine welds in TIG method with high-frequency arc ignition (HF) or with touch ignition (LIFT ARC).
-  Caution  Extension cables must not have conductors with a smaller cross section than 3x2,5 mm². The machine can be operated on a single-phase electric generator 9 kVA for machine PERUN 160 T HF PULSE and 11 kVA for machine PERUN 200 T HF PULSE (1x230V/50Hz) and more, which has ensured voltage stabilization ± 10%. Generators with lower power can damage the machine.**
13. It is necessary to protect the machine against:
 - a. Moisture and rain
 - b. Chemically aggressive environments
 - c. Mechanical damage
 - d. Draft and possibly ventilation of neighboring machines
 - e. Excessive overloading – exceeding tech. parameters
 - f. Rough treatment

ELECTROMAGNETIC COMPATIBILITY

The welding device is in terms of interference designed primarily for industrial areas. It meets the requirements of EN 60974-10 class A and it isn't designed for using in residential areas, where the electrical energy is supplied by public low-voltage power supply network. It can be here potential problems with ensuring of electromagnetic compatibility in this areas, due to interference caused by power lines as well as the radiated interference.

During operation, the device may be the source of interference.

 **Caution**  We warn users, that they are responsible for possible interference from welding.

4. TECHNICAL DATA

PERUN 160 T HF PULSE			
Method		MMA	TIG
Mains voltage	V/Hz	1x230/50-60	
Welding current range	A	5 - 160	5 - 160
Open-circuit voltage U_{20}	V	88	88
Mains protection	A	16 @	
Max. effective current I_{1eff}	A	16,0	14,4
Welding current (DC=100%) I_2	A	80	110
Welding current (DC=60%) I_2	A	105	140
Welding current (DC=x%) I_2	A	20%=160	40%=160
Protection		IP23S	
Standards		EN 60974-1, EN 60974-10 cl. A	
Dimensions (w x l x h)	mm	160 x 460 x 280	
Weight	kg	7,0	

PERUN 200 T HF PULSE			
Method		MMA	TIG
Mains voltage	V/Hz	1x230/50-60	
Welding current range	A	5 - 200	5 - 200
Open-circuit voltage U ₂₀	V	89,0	86,0
Mains protection	A	16 @	
Max. effective current I _{1eff}	A	16,0	15,0
Welding current (DC=100%) I ₂	A	85	120
Welding current (DC=60%) I ₂	A	105	140
Welding current (DC=x%) I ₂	A	10%=200	25%=200
Protection		IP23S	
Standards		EN 60974-1, EN 60974-10 cl. A	
Dimensions (w x l x h)	mm	160 x 460 x 280	
Weight	kg	7,0	

Note on SW limitations of loaders:

SW limitation is active at the following load:

- PERUN 160 T HF PULSE: I₂ = 150 - 160 A
- PERUN 200 T HF PULSE: I₂ = 190 - 200 A

The running time of the machine is limited to 5 minutes. Subsequently the LED of overheating the machine **V19** lights up and the error message „**E 09 – SW protection of overheating**“ appears on the display **V31** and the output current is blocked for 5 minutes. After this time, the LED of overheating the machine **V19** goes out, the error message **E 09** disappears from the display **V31** and the operation of the machine is unlocked.



5. EQUIPMENT

PART OF THE DELIVERY

Item No.	Description	Picture
5.0311	PERUN 160 T HF PULSE	
5.0316	PERUN 200 T HF PULSE	

ACCESSORIES ON REQUEST

Item No.	Description	Picture
VM0151-1	Hose Gas 3m G1/4-G1/4	
T24ST	Torch T2 4m 35-50 arc ST	
T24STPOT	Torch T2 4m 35-50 arc ST with potentiometer	
T24STUD	Torch T2 4m 35-50 arc ST UD	
T28ST	Torch T2 8m 35-50 arc ST	
T28STPOT	Torch T2 8m 35-50 arc ST with potentiometer	
T28STUD	Torch T2 8m 35-50 arc ST UD	
VM0253	Welding Cable Set 2x 3m 35-50 200A	
6008	Pressure Reducer FIXICONTROL Ar 2 manometers GCE	
7029	Belt PERUN	
S7SUN9B	Welding Helmet S9B Shooting Blue Shark	

S7SUN20B	Welding Helmet S20B Flipper	
5.0174ST	Foot Pedal Remote CTRL 3 m PERUN, PEGAS incl. Connector ST	
5.0139ST	DOV PERUN remote control 10m ST	

6. OPERATOR CONTROLS

MAIN PARTS

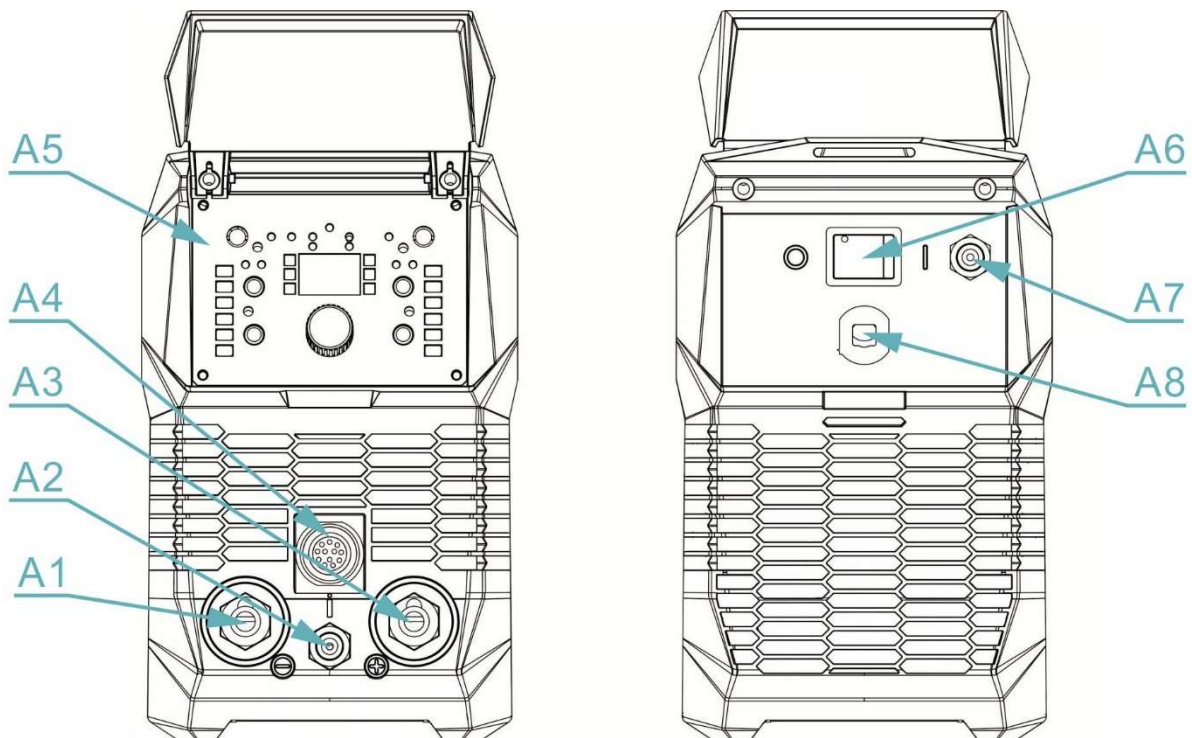

Figure 1. Main parts of the machine

Pos.	Description
A1	Quick connector (-)
A2	Gas outlet TIG connector
A3	Quick connector (+)
A4	TIG torch control connector
A5	Operating panel
A6	ON/OFF switch
A7	Gas inlet connector
A8	Mains cable

OPERATING PANEL

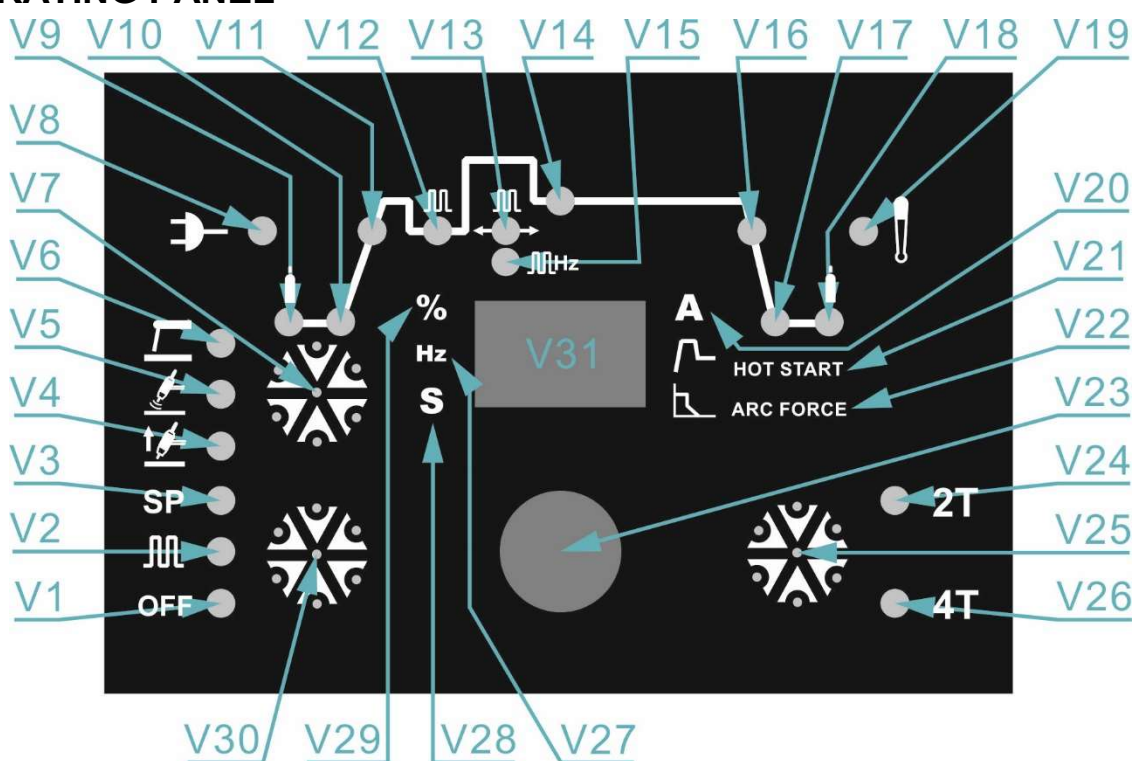

Figure 2. Operating panel

Pos.	Description
V1	LED – spot welding OFF
V2	LED – pulse mode ON
V3	LED – spot welding ON
V4	LED – TIG LIFT method selected (touch ignition)
V5	LED – TIG HF method selected

V6	LED – MMA method selected (coated electrode)
V7	Welding method switch – MMA / TIG HF / TIG LIFT
V8	LED ON
V9	LED – pre gas (only for TIG). 0,1 – 2,0 (0,1s).
V10	LED – start current (only for TIG). 5 – 160 (50A).
V11	LED – up slope (only for TIG). 0 – 25 (0s).
V12	LED – base current (only for TIG). 5 – 160 (50A).
V13	LED – pulse width (only for TIG). 5 – 95 (50%).
	LED of setting the time of the spot for TIG (can only be selected in TIG HF 2T)
V14	LED – welding current. 5 – 160 (80A).
	LED – welding current for SP function. 5 – 160 (80A).
V15	LED – pulse frequency (only for TIG). 0.5 – 200 (100Hz).
V16	LED – down slope (only for TIG). 0 – 25.0 (0s).
V17	LED – final current (only for TIG). 5 - 160 (5A). Selectable in 2T and 4T.
V18	LED – post gas (only for TIG). 0,1 – 20,0 (10s).
	LED – post gas for SP function. 0,1 – 10 (0,1s).
V19	LED ALARM If illuminated there is under or over voltage in the mains or the machine is overheated.
V20	LED – MMA welding current
V21	LED HOT START (only for MMA). 0 – 10 (5).
V22	LED ARC FORCE (only for MMA). 0 – 10 (5).
V23	Encoder
V24	LED 2T (two stroke)
V25	Button for mode selection - 2T or 4T
V26	LED 4T (four stroke)
V27	LED – values on the display V31 are in Hz
V28	LED – values on the display V31 are in s
V29	LED – values on the display V31 are in %

V30	Spot welding + pulse mode switch
V31	Display

PULSE

The welding process in which the pulsating current optimizes the welding bath. The welding current pulses from the minimum value (base current) to the maximum value and the pulse frequency can be set. This function is used for welding thin materials.

SP (spot welding)

The welding process in which there is a spot welding mainly of thin-walled materials at a set current and for a preset time.

The curve on the machine control panel is limited for this mode, by means of the encoder **V23** you can select: pre gas – LED **V9**, welding current – LED **V14**, post gas – LED **V18** and setting the time of the spot – LED **V13**. The SP function is only available in TIG HF 2T mode.

7. GETTING STARTED

Getting started must be consistent with technical data and conditions of use.

GETTING STARTED MMA – COATED ELECTRODE

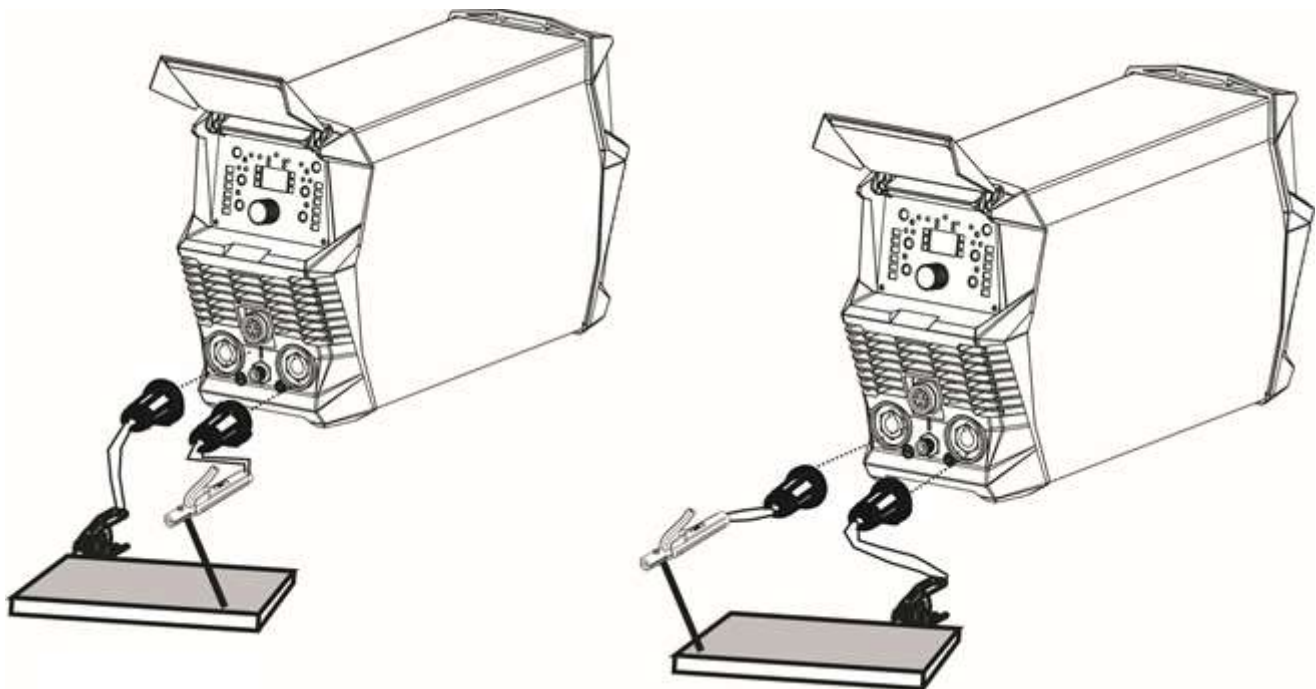

Figure 3. MMA welding set up

1. Insert the mains plug into a suitable 1x230 V mains socket.
2. Connect the welding cables to the panel quick connectors (+) **A3** and (-) **A1** according the instruction on the electrodes packing.

3. Switch the machine on by means of the ON/OFF switch **A6**.
4. By means of the welding method switch **V7** select MMA method. The corresponding LED **V6** will light up.
5. By means of the encoder **V23** set the welding current. The values will be showed on the display **V31**.
6. It is possible to change the settings of the **HOT START** (increase of current during arc ignition time), **ARC FORCE** (an automatic increase of the welding current in case the electrode touches the welding piece) by means of the encoder **V23**.

 **NOTE**  Prevent touching the electrode any metal material for in this mode the quick connectors **A3** and **A1** are under current.

7. Insert the coated electrode into the electrode holder, connect the clamps of the ground cable to the welding piece and you may start welding.

TABLE OF ELECTRODE CONSUMPTION DURING WELDING

Electrode diameter [mm]	Range of welding current [A]	Total electrode length [mm]	Weight of boiled electrode without slag [g]	Boiled electrode time [s]	Weight of boiled electrode without slag per 1 second [g/s]
1,6	30 - 55	300	4	35	0,11
2,5	70 - 110	350	11	49	0,22
3,2	90 - 140	350	19	60	0,32
4,0	120 - 190	450	39	88	0,44

GETTING STARTED TIG

TIG TORCH CONNECTION SCHEMA

5737 CONNECTOR ST 12 PIN MALE		
PIN NO.	TORCH WITH POTENTIOMETER	UP-DOWN TORCH
1	/	/
2	/	/
3	POTENTIOMETER (+)	/
4	POTENTIOMETER (CENTER)	/
5	POTENTIOMETER (-)	/
6	/	UP
7	/	DOWN
8	START/STOP	START/STOP
9	START/STOP	START/STOP (GND)
10	SHORT CIRCUIT	/
11		/
12	/	/

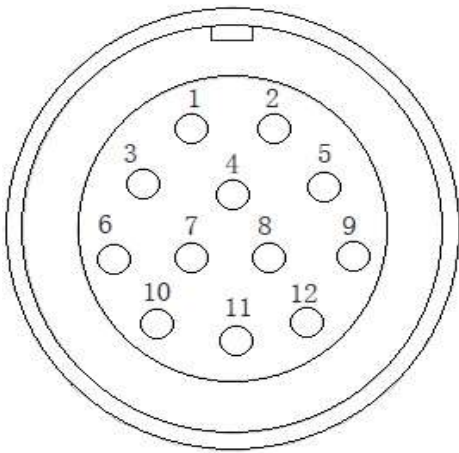

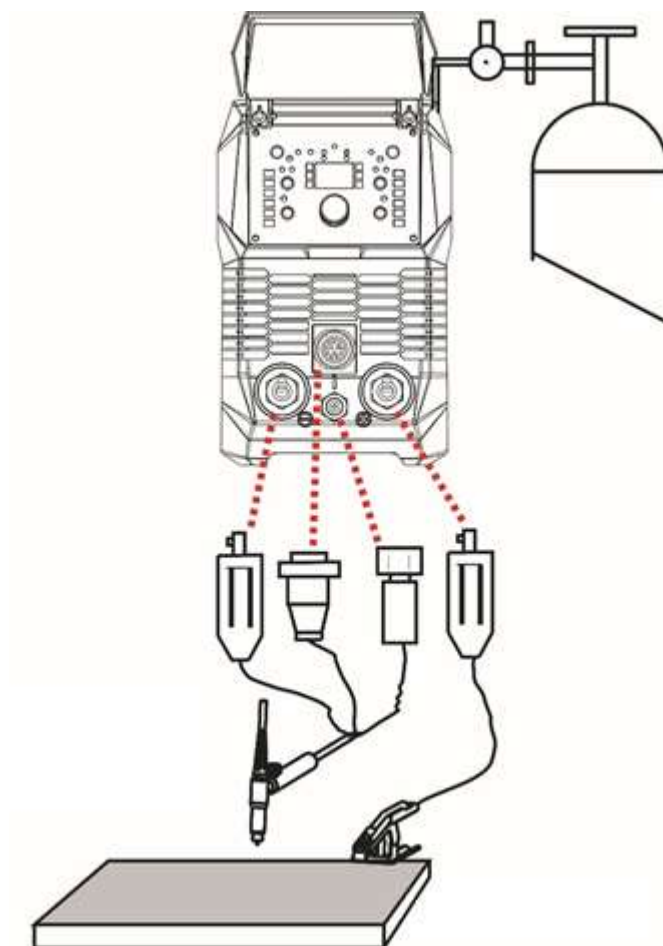

Figure 4. TIG welding set up

1. Insert the mains plug into a suitable 1x230 V mains socket.
2. Connect the TIG torch to the panel quick connector (-) **A1**.
3. Connect the earthing cable to the panel quick connector (+) **A3**.
4. Switch the machine on by means of the ON/OFF switch **A6**.
5. By means of the welding method switch **V7** select TIG method. The corresponding LEDs **V4** and **V5** will light up.
6. Connect the to the reduction valve on the gas cylinder and on the gas inlet connector **A7** on the rear panel.
7. Connect the gas hose of the TIG torch onto gas outlet connector **A2**.
8. Connect the torch control connector onto the matching connector **A4**.
9. By means of the encoder **V23** set the welding current. The values will be showed on the display **V31**.

TABLE OF CONSUMPTION DURING TIG WELDING

Wolfram electrode diameter [mm]	Argon flow [l/min]
	Steel / stainless steel
0,5	3 – 4
1,0	3 – 5
1,6	4 – 6
2,4	5 – 7
3,2	5 – 9

REMOTE CONTROL

PERUN 160-200 T HF PULSE supports these kinds of remote controls:

1. TIG torch with UP-DOWN buttons / with potentiometer
2. Standard separate remote control for changing the value of the welding current (only for MMA)
3. Foot pedal (only for TIG)

All three models of remote controls can be connected by means of the front panel connector **A4**.

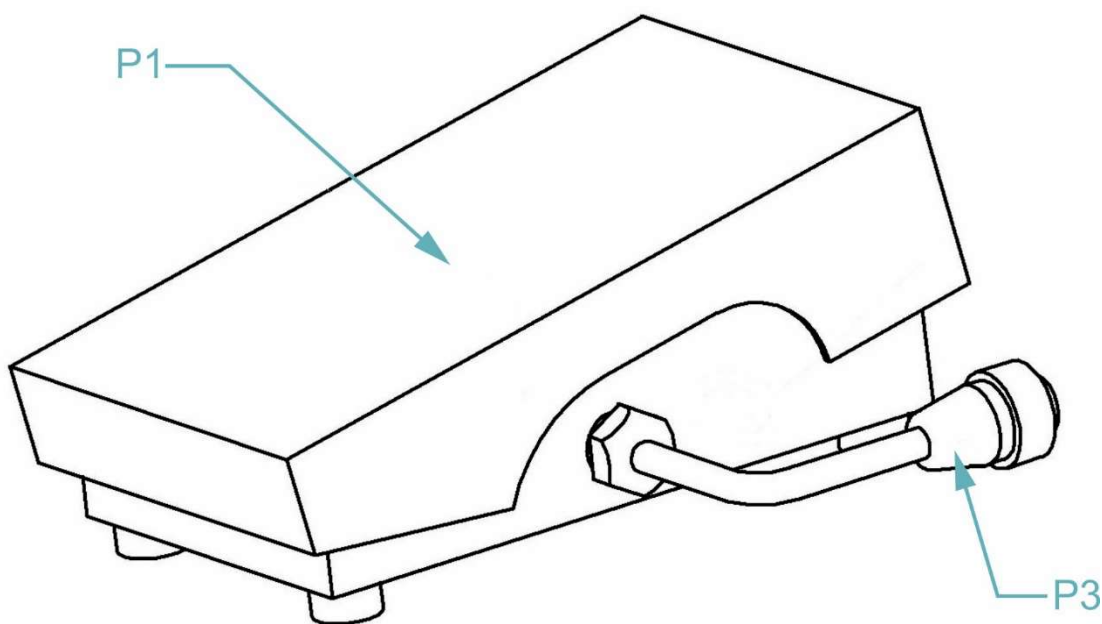

Figure 5. Foot pedal remote control

Pos.	Description
P1	Stepping surface
P3	Connector (connect to matching connector A4 on the front panel)

1. When you connect the **P3** connector to matching connector on the front panel **A4** the function setting the current from the front panel will be blocked.
2. Set by the encoder **V23** the maximal required value of the current.

3. Set the machine to the mode **2T**.
4. By pressing the stepping surface **P1** down you start the welding process. The value of the welding current depends on the level of pressing the stepping surface. To reach the maximal current, set by encoder **V23**, requires to gently pressing to the lowest position of the stepping surface **P1**. The set current will be displayed on the display **V31**.
5. The welding process ends after releasing the stepping surface **P1**.

8. TWO STROKE AND FOUR STROKE IN TIG MODE

TWO STROKE – 2T

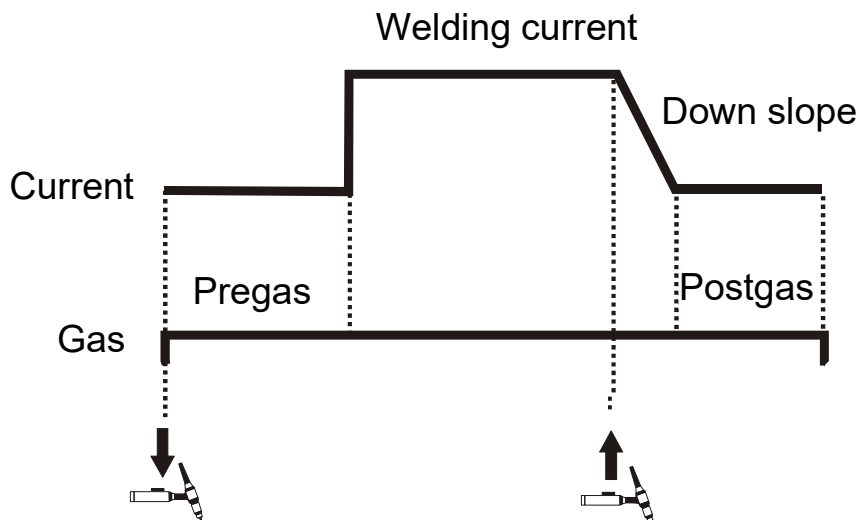

FOUR STROKE – 4T

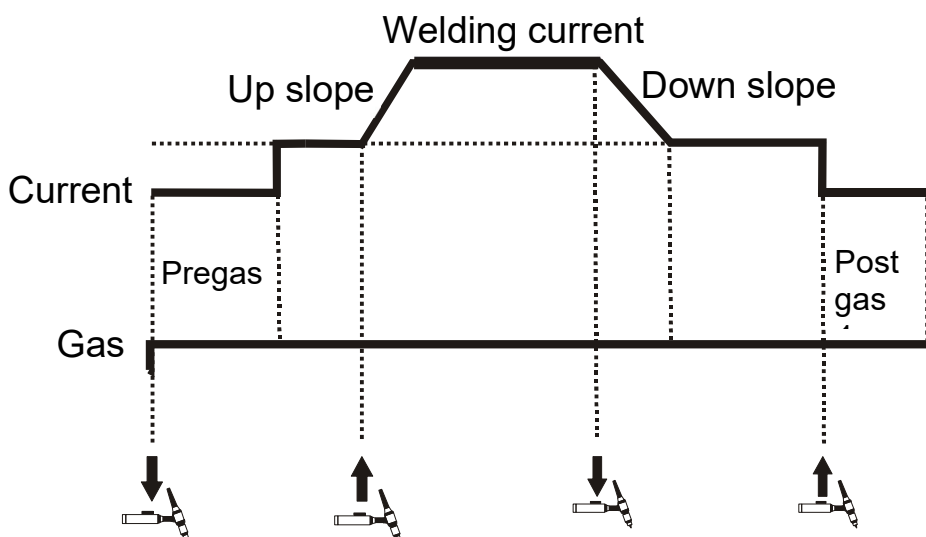

BILEVEL – SECOND WELDING CURRENT

When the machine is in 4T mode, there is always active the BILEVEL function. The value of the second current is automatically set to 50% of the pre-set value of the main welding current. To enter the second welding current press the torch

button for a short time and release it. To get back to the main welding current press the torch button for a short time and release it.

9. JOBS

JOBs are available in both methods – MMA and TIG.
The welding machine has a choice from 10 JOBs.

HOW TO SAVE PARAMETERS TO THE JOB

1. Parameters, which you want to save to the JOB, set by means of the encoder **V23**. (By short pressing the encoder **V23** switch between particular parameters of the curve or functions.)
2. As soon as you will have saved all parameters, then by long pressing the encoder **V23** get into the JOBs menu. The display **V31** will show **-S-**. In the JOBs menu are two positions: **-S-** (Save) and **-L-** (Load).
3. By short pressing the encoder **V23** confirm the message **-S-** on the display **V31** to save your choice of parameters or functions. The display **V31** will show numbers from 2 to 11 for particular JOBs. Rotate the encoder **V23** to select the desired JOB number, into which you want to save your selected parameters, then confirm your choice by short pressing the encoder **V23**.

HOW TO LOAD THE SAVED JOB

1. By long pressing the encoder **V23** get into the JOBs menu. The display **V31** will show **-S-**.
2. Rotate the encoder **V23** to move to the position **-L-**. By short pressing the encoder **V23** confirm the position **-L-**.
3. The display **V31** will show numbers from 2 to 11 for particular JOBs. Rotate the encoder **V23** to select the desired JOB number, from which you want to load your selected parameters, then confirm your choice by short pressing the encoder **V23**.

HOW TO DELETE SAVED PARAMETERS FROM THE JOB

It is not possible to delete parameters from the JOB, they can be only replaced by new parameters. To save new parameters, see the chapter HOW TO SAVE PARAMETERS TO THE JOB above.

10. RESET

The factory reset is performed as follows:

1. By long pressing the encoder **V23** get into the JOBs menu. The display **V31** will show **-S-**.
2. Rotate the encoder **V23** to move to the position **-L-**. By short pressing the encoder **V23** confirm the position **-L-**.

3. Rotate the encoder **V23** and select the number **1**, which is designed for **factory reset**, then confirm your choice by short pressing the encoder **V23**.

11. ROUTINE MAINTENANCE & INSPECTION

1. The only routine maintenance required for the PERUN range of machines is a thorough cleaning and inspection, with the frequency depending on the usage and the operating environment.



2. Disconnect the PERUN from the mains supply voltage before disassembling.
3. Special maintenance is not necessary for the control unit parts in the Welder. If these parts are damaged for any reason, replacement is recommended.





4. Do not blow air into the welder during cleaning. Blowing air into the welder can cause metal particles to interfere with sensitive electronic components and cause damage to the welder.
5. To clean the welder, disconnect it from the mains supply voltage then open the enclosure and use a vacuum cleaner to remove any accumulated dirt and dust. The welder should also be wiped clean. If necessary, solvents that are recommended for cleaning electrical apparatus may be used.
6. Troubleshooting and repairing of PERUN welding equipment should only be carried out only by suitably qualified or competent person.
7. A 'competent person' must be a person who has acquired through training, qualification or experience, or a combination of them, the knowledge and skills enabling that person to safely carry out a risk assessment and repairs to the electrical equipment in question.
8. The person carrying out the servicing needs and repairs must know what to look at, what to look for and what to do.

12. STATEMENT OF WARRANTY

1. In accordance with the warranty periods stated below, ALFA IN guarantees the proposed product to be free from defects in material or workmanship when operated in accordance with the written instructions as defined in this operating manual.
2. ALFA IN welding products are manufactured for use by commercial and industrial users and trained personnel with experience in the use and maintenance of electrical welding and cutting equipment.
3. ALFA IN will repair or replace, at its discretion, any warranted parts or

components that fail due to defects in material or workmanship within the warranty period. The warranty period begins on the date of sale to the end user.

4. If warranty is being sought, please contact your ALFA IN product supplier for the warranty repair procedure.
5. ALFA IN warranty will not apply to:
6. Equipment that has been modified by any other party other than ALFA IN's own service personnel or with prior written consent obtained from ALFA IN Service Department.
7. Equipment that has been used beyond the specifications established in the operating manual.
8. Installation not in accordance with the installation/operating manual.
9. Any product that has been subjected to abuse, misuse, negligence or accident.
10. Failure to clean and maintain (including lack of lubrication, maintenance and protection), the machine as set forth in the operating, installation or service manual.
11. Within this operating manual are details regarding the maintenance necessary to ensure trouble free operation.
12.  NOTE 
13. Warranty repairs must be performed by either an ALFA IN Service Centre, an ALFA IN distributor or an Authorised Service Agent approved by the company ALFA IN.
14. As a warranty list serves proof of purchase (invoice) on which is the serial number of the machine, eventually a warranty list on the last page of this manual.

13. DISPOSAL



Only for EU countries. Do not dispose of electric tools together with household waste material.

■ In accordance with European Council Directive 2002/96/EC on electrical and electronic equipment waste and its implementation in accordance with national law, electric tools that have reached the end of their service life must be collected separately and returned to an environmentally compatible recycling facility.

14. WARRANTY LIST

As a warranty list serves proof of purchase (invoice) on which is the serial number of the machine, eventually a warranty list below, which is filled in by an authorized dealer.

Serial number:	
Day, month (written in words) and year of sale:	
Stamp and dealer signature:	