

**PLASMA CUTTING MACHINE**

**PEGAS 41 PLASMA PFC**

**OPERATING MANUAL**

**CONTENT**

1.	INTRODUCTION .....	3
2.	SAFETY INSTRUCTIONS AND WARNINGS .....	4
3.	CONDITIONS OF USE .....	7
4.	TECHNICAL DATA .....	8
5.	MAIN PARTS OF THE MACHINE .....	10
6.	ACCESSORIES .....	11
7.	GETTING STARTED .....	16
8.	CUTTING .....	18
9.	MAINTENANCE .....	20
10.	STATEMENT OF WARRANTY .....	22
11.	DISPOSAL .....	23
12.	WARRANTY LIST .....	23

## 1. INTRODUCTION

Congratulations on your new ALFA IN product. We are proud to have you as our customer and will strive to provide you with the best service and reliability in the industry.

This Operating Manual has been designed to instruct you on the correct use and operation of your ALFA IN product. Your satisfaction with this product and its safe operation is our ultimate concern. Therefore please take the time to read the entire manual, especially the safety precautions. They will help you to avoid potential hazards that may exist when working with this product.

Read and understand this entire manual and your employer's safety practices before installing, operating, or servicing the equipment. While the information contained in this manual represents the manufacturer's best judgement, the manufacturer assumes no liability for its use.

Machine PEGAS 41 PLASMA PFC is designed for cutting metal on the basis of modern technology cutting material through a thin beam plasma gas.

PEGAS 41 PLASMA PFC is equipped by Power Factor Correction (PFC), which allows operation on single phase voltage networks 110 V – 230 V.

PEGAS 41 PLASMA PFC is designed for high-quality cutting of materials up to 15 mm thick carbon steel (for more information, see instructions below). Productive cutting of carbon steel can be to a thickness of 10 mm. At lower demands on the quality of the cut can be cut through (separate) the material thickness to 20 mm.

We reserve the law of adjustments and changes in case of printing errors, change of technical paramaters, accessories etc. without previous notice. These changes may not be reflected in the manuals for use in paper or electronic form.



## 2. SAFETY INSTRUCTIONS AND WARNINGS

1. OPERATION AND MAINTENANCE OF PLASMA ARC EQUIPMENT CAN BE DANGEROUS AND HAZARDOUS TO YOUR HEALTH.
2. Plasma arc cutting produces intense electric and magnetic emissions that may interfere with the proper function of cardiac pacemakers, hearing aids, or other electronic health equipment. Persons who work near plasma arc cutting applications should consult their medical health professional and the manufacturer of the health equipment to determine whether a hazard exists.
3. Once the packing has been opened, make sure that the machine is not damaged. If in any doubt, call the service centre.
4. This equipment must only be used by qualified personnel.
5. During installation, any electric work must only be carried out by trained personnel.
6. The machine must be used in a dry place with good ventilation.
7. Make sure that no metal dust can be drawn in by the fan inside the machine, as this could cause damage to the electronic circuits.
8. It is prohibited to connect more than one INVERTER generator in series or in parallel.
9. When installing the machine, follow the local regulations on safety.
10. The position of the machine must allow easy access by the operator to the controls and connectors.
11. When the cutting machine is operating, all its covers and doors must be closed and well fixed.
12. Do not expose the cutting machine to direct sunlight or to heavy rain. This equipment conforms to protection rating IP23S.
13. The operator must wear gloves, clothes, shoes, and a helmet or a welder's helmet, which protect and are fire-resistant in order to protect him against electric shock, flashes and sparks from cutting.
14. The operator must protect his eyes with safety visor or mask designed for welding, fitted with standard safety filters. He should also be aware that during plasma cutting ULTRAVIOLET RADIATION is emitted. Therefore it is vital that his face is also protected from radiation. Ultraviolet rays produce the same harmful effect as sun burning on unprotected skin.
15. The operator is obliged to warn anyone near the cutting area of the risks that cutting involves and to arrange to provide adequate protection equipment.
16. Keep all fumes and gases from the breathing area.
17. Keep your head out of the fume plume.
18. Use an air-supplied respirator if ventilation is not adequate to remove all fumes and gases.
19. The kinds of fumes and gases from the plasma arc depend on the kind of metal being used, coatings on the metal, and the different

processes. You must be very careful when cutting or welding any metals which may contain one or more of the following:

Antimony	Chromium	Mercury
Nickel	Cobalt	Arsenic
Barium	Copper	Selenium
Beryllium	Lead	Silver
Cadmium	Manganese	Vanadium

20. Always read the Material Safety Data Sheets (MSDS) that should be supplied with the material you are using. These MSDSs will give you the information regarding the kind and amount of fumes and gases that may be dangerous to your health.
21. It is very important to arrange for sufficient ventilation, especially when cutting in enclosed spaces. We suggest using suitable fume extractors to prevent the risk of intoxication by fumes or gas generated by the cutting process.
22. Noise can cause permanent hearing loss. Plasma arc processes can cause noise levels to exceed safe limits. You must protect your ears from loud noise to prevent permanent loss of hearing.
23. To protect your hearing from loud noise, wear protective ear plugs and/or ear muffs. Protect others in the workplace.
24. Noise levels should be measured to be sure the decibels (sound) do not exceed safe levels.
25. The operator must ensure all flammable materials are removed from the work area to avoid any risk of fire.
26. The operator must NEVER cut containers that have previously contained petrol, lubricants, gas or similar flammable materials, even if the container has been empty for a considerable time. THERE IS A VERY HIGH RISK OF EXPLOSION.
27. The operator must be aware of all the special regulations which he needs to conform to when cutting in enclosed spaces with a high risk of explosion.
28. To prevent electric shock, we strongly suggest the following rules:
  - a. Do not work in a damp or humid environment.
  - b. Do not use the machine if its cables are damaged in any way.
  - c. Make sure that the earthing system of the electric equipment is correctly connected and operational.
  - d. The operator must be insulated from the metal components connected to the return wire.
  - e. The earthing of the piece being worked could increase the risk of injury to the operator.
29. EN 60974-1 Standard: Open-circuit voltage. During the operation of the machine, the highest voltage, with which it is possible to come into contact, is the open-circuit voltage between the clamps. In our generator this voltage is 320V.

30. The maximum open-circuit voltage of the plasma machines is established by national and international standards (EN 60974-1) depending on the type of current to be used, on its waveform and on the hazards arising from the work place. These values are not applicable to the strike currents and those for stabilisation of the arc that could be above it.

31. The open-circuit voltage, for as many adjustments as possible, must never exceed the values relating to the various cases shown in the following table:

Case	Working conditions	Open-circuit voltage	
1	Places with increased risk of electric shock	DC current: 113V peak value	AC current: 68V peak value and 48V effective
2	Places without increased risk of electric shock	DC current: 113V peak value	AC current: 113V peak value and 80V effective
3	Torches held mechanically with increased protection for the operator	DC current: 141V peak value	AC current: 141V peak value and 100V effective
4	Plasma cutting	DC current: 500V peak value	

32. In case 1, the dc machines with rectifier must be built in such a way that, in case of a fault developing in the rectifier (for example open circuit, short circuit or lack of power), the permitted values cannot be exceeded. The plasma cutting machines of this type can be marked with the symbol:



33. Before opening the machine switch off the machine and disconnect it from the power socket.

34. Only personnel authorised by this company can carry out maintenance on the machine.

## PROTECTIVE UTILITIES

1. Welding helmet with filter shade at least 10
2. Welding gloves
3. Welding apron and cloth
4. Welding boots

## RISK OVERVIEW

1. Risk of electric shock
2. Ultraviolet light and light radiation
3. Risk of inhaling gas fumes and dust particles
4. Burns

## 5. Noise



1. It is forbidden to operate a machine with damaged insulation of the cutting torch or supply cable.
2. Never operate the machine taken down or damaged covers.
3. It is forbidden to operate the machine in wet environments and outdoors in rain or snow.
4. Ensure proper grounding clamping pliers, which also reduces the risk of electric shock.
5. Use prescribed protective utilities, keep them dry.
6. Plasma arc cutting produces intense electric and magnetic emissions that may interfere with the proper function of cardiac pacemakers, hearing aids, or other electronic health equipment. Persons who work near plasma arc cutting applications should consult their medical health professional and the manufacturer of the health equipment to determine whether a hazard exists.
7. Never aim the torch against the eyes, body or other person.

## 3. CONDITIONS OF USE

1. This equipment must only be used by qualified personnel.
2. During installation, any electric work must only be carried out by trained personnel.
3. Device complies with IEC 61000-3-12.
4. Do not expose the plasma machine to direct sunlight or to rain or snow. This equipment conforms to protection rating IP23S.
5. Working ambient temperature between -10 and +40 °C.
6. Relative humidity below 90% at +20 °C.
7. Up to 3000 m altitude.
8. Place the machine the way that the cooling air can enter the vents without restriction to. It is necessary to ensure that no impurities, especially metal particles, are not drawn into the machine.
9. Cutting machine in terms of interference suppression is intended primarily for industrial premises. In the case of use of other areas may be need for special measures (see EN 60974-10).
10. The machine must be protected against
  - a. Moisture and rain and snow
  - b. Mechanical damage
  - c. Draft and any ventilation of neighbouring machine
  - d. Excessive overloading - crossing technical parameters
  - e. Rough handling

## ELECTROMAGNETIC COMPATIBILITY

The welding device is in terms of interference designed primarily for industrial areas. It meets the requirements of EN 60974-10 class A and it isn't designed for using in residential areas, where the electrical energy is supplied by public low-voltage power supply network. It can be here potential problems with ensuring of electromagnetic compatibility in this areas, due to interference caused by power lines as well as the radiated interference.

During operation, the device may be the source of interference.

 Caution 

We warn users, that they are responsible for possible interference from welding.

## 4. TECHNICAL DATA

Method		Plasma cutting		
Mains voltage	V/Hz	1x110/50-60	1x230/50-60	
Cutting current range	A	20 - 30	20 - 40	
Open-circuit voltage $U_{20}$	V	320		
Mains protection	A	25 @	16 @	
Max. effective current $I_{1eff}$	A	20,4	15,4	
Cutting current (DC=100%) $I_2$	A	20	28	
Cutting current (DC=60%) $I_2$	A	22	33	
Cutting current (DC=x%) $I_2$	A	35%=30	50%=40	
Max. productive cut. thickness - carbon steel	mm	8	10	
Max. Cutting thickness - carbon steel (separate mat.)	mm	15	20	
Quality cutting thickness	Carbon steel	mm	10	15
	Stainless steel	mm	8	12
	Aluminium	mm	6	10
	Copper	mm	3	4
Max. Input pressure	bar	8,5		
Working pressure (torch PT-60/ABICUT 45)	bar	4,4 – 5,0/5,0		
Air consumption (torch PT-60/ABICUT 45)	l/min	150/119		
Arc ignition		pneu-mechanic		
Current regulation		continuous		
Protection		IP 23S		
Standards		EN 60974-1, EN 60974-10 cl. A		
Dimensions (w x l x h)	mm	148 x 490 x 295		
Weight	kg	8,4		



 **IMPORTANT NOTICE** 

Please keep in mind that at the set maximum cutting current parameters, the current consumption from the mains increases significantly when the distance between the torch and the material is increased (arc extension).

This can cause unwanted tripping of the circuit breaker. This phenomenon can also occur if the consumable material (nozzle, electrode) is worn out.

**Precautions:**

It is recommended to cut at a constant distance from the material (as small as possible) and to maintain select an adequate cutting current (do not use high cutting current values unnecessarily).

## 5. MAIN PARTS OF THE MACHINE

### FRONT AND REAR PANELS

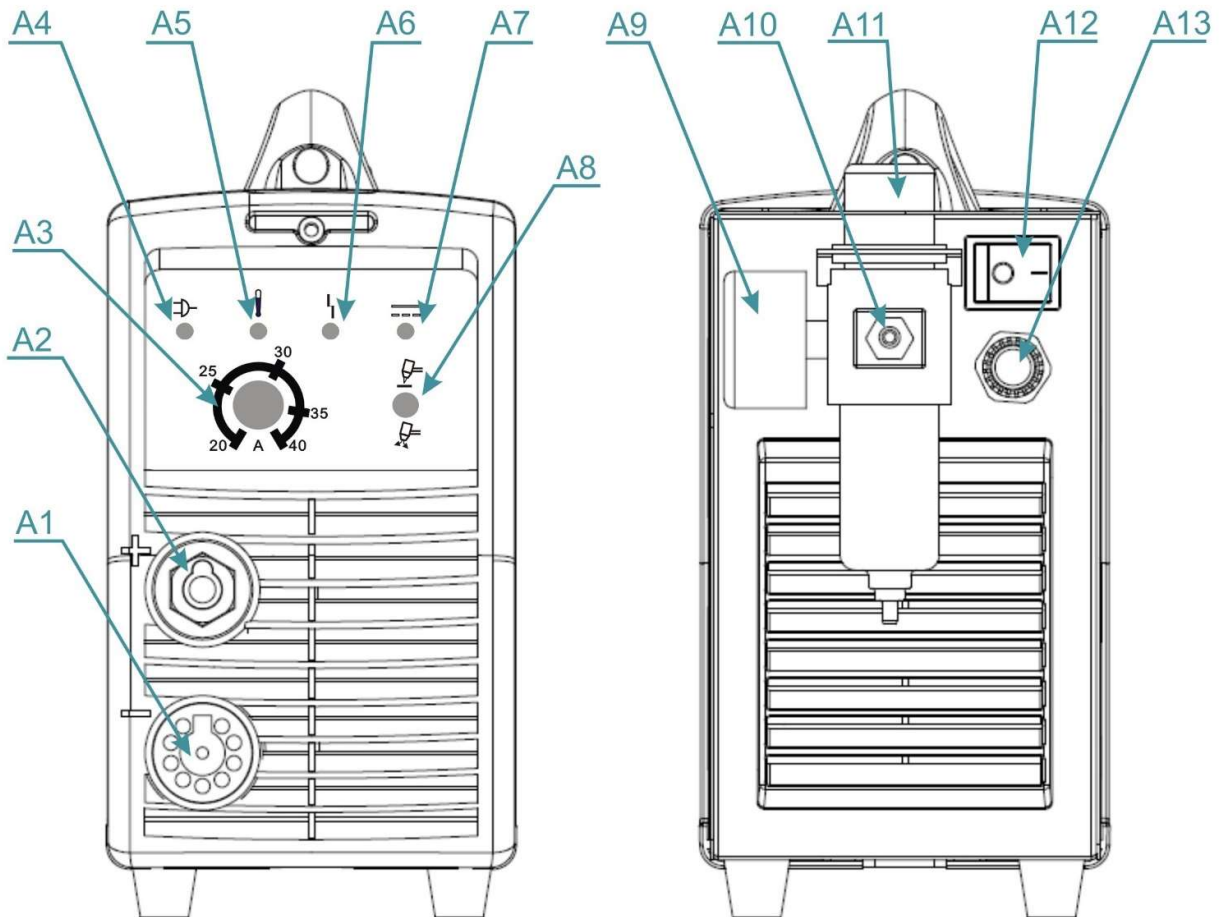







Fig. 1 Main parts of the machine

Pos.	Description
A1	Connector - torch
A2	Quick connector – earthing cable
A3	Potentiometer-set cut current
A4	 LED indicator – when illuminated, the machine is ON
A5	 LED indicator. If the LED illuminates the thermo-switch is disconnected. In such a case leave the machine on to cool down. Second warning is when the mains voltage is over 270 V.
A6	 LED Error 1. LED illuminates and the air valve regularly opens and closes - there is a shortcut among the shield cup and the cutting tip.

	<p>2. LED illuminates and the air valve regularly opens and closes - the cutting tip and the electrode are not fitted properly.</p> <p>3. LED flashes – there is not shield cup or the shield cup is not fitted properly.</p> <p>4. LED illuminates – low air pressure</p>
A7	 LED torch burning – illuminates when the torch trigger is pressed. On the torch is voltage.
A8	<p>Switch</p> <p> Setting of gas flow</p> <p> Continuous cutting</p>
A9	Manometer
A10	Gas fitting
A11	Controller
A12	Switch ON/OFF
A13	Mains cable

## 6. ACCESSORIES ON REQUEST

Pos.	Item No	Description
	5081	Circular Cutting Attachment PT-60
	742.D121.1	Circular Cutting Attachment ABICUT 45
24	5302	Air filter AT 1000
25	5304	Set for filter AT 1000
	S777c.	Welding Helmet Barracuda S777C Black
	5048	Torch Plasma PT-60 6m
	381.0001.1	Torch ABICUT 45 6 m ALFA IN
	7101	Silicone Lubricant Brutto 6 g
	7102	Silicone Lubricant Brutto 9 g



Fig. 2 Circular Cutting Attachment  
PT-60



Fig. 3 Air filter AT 1000

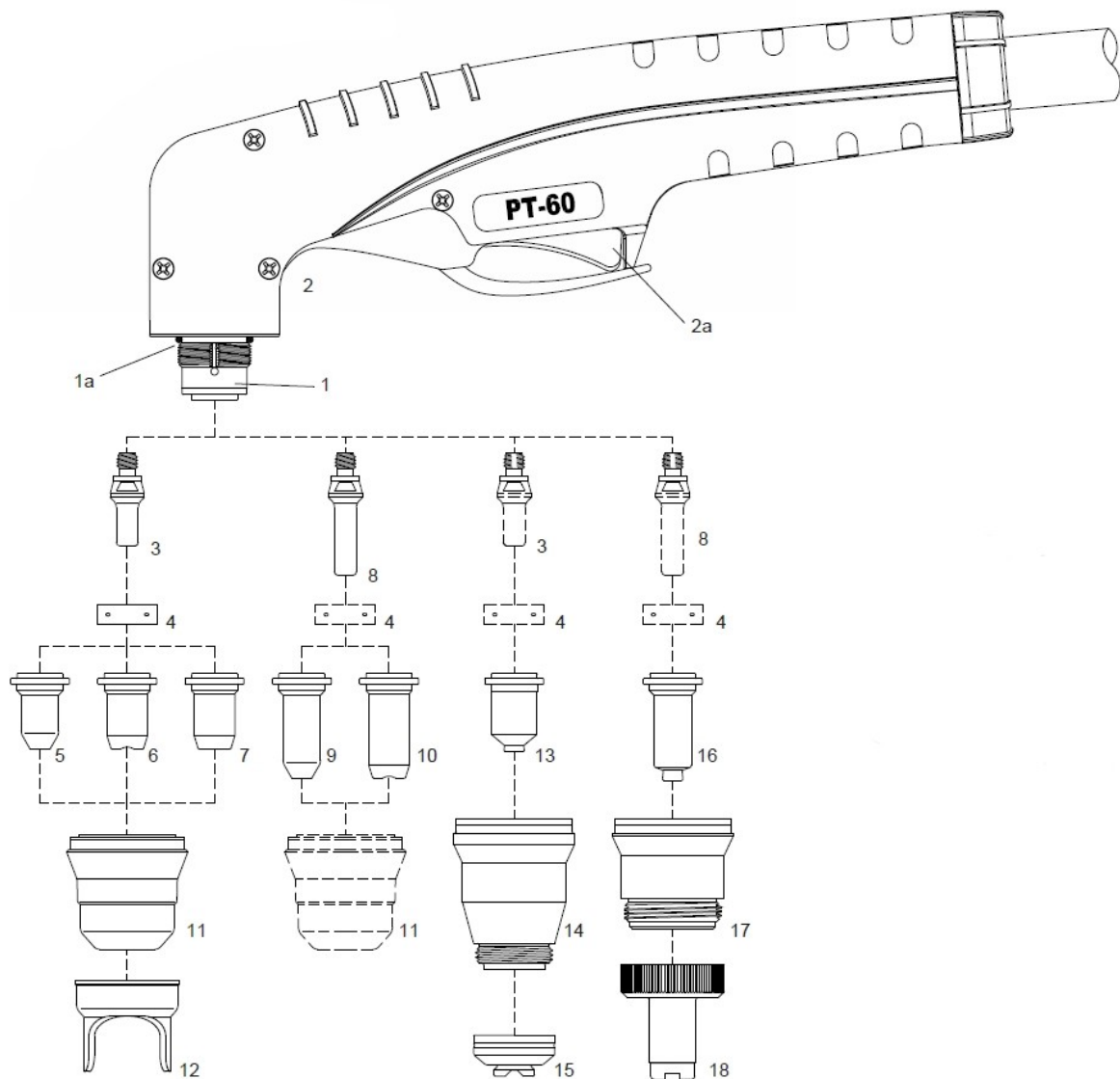

Fig. 4a Torch PT-60

Pos.	Item No	Description
<b>1</b>	<b>5050</b>	<b>PT-60 Hand Torch Head 70deg</b>
<b>1a</b>	<b>5052</b>	<b>O-Ring PT-60, SCP 60, SCB 50 (pkg.2)</b>
<b>2</b>	<b>5053</b>	<b>Hand Handle with Switch</b>
<b>2a</b>	<b>5011</b>	<b>Switch</b>
<b>3</b>	<b>5055</b>	<b>Electrode, Back Striking (pkg.10)</b>
<b>4</b>	<b>5056</b>	<b>Swirl Ring (pkg.2)</b>
5	5058	Tip, Contact Cutting, Ø 0.8 (20-30A), Back Striking (pkg.10)
5	5057	Tip, Contact Cutting, Ø 0.65 (10-20A), Back Striking (pkg.10)
6	5060	Tip, Contact Cutting, Ø 0.9 (30-40A), Back

		Striking (pkg.10)
7	5061	Flat Tip, Cutting, Ø 1.0 (40-50A), Back Striking (pkg.10)
<b>7</b>	<b>5062</b>	<b>Flat Tip, Cutting, Ø 1.1 (50-60A), Back Striking (pkg.10)</b>
8	5063	Extended Electrode, Back Striking (pkg.10)
9	5064	Extended Tip, Contact Cutting, Ø 0.65 (10-20A), Back Striking (pkg.10)
9	5065	Extended Tip, Contact Cutting, Ø 0.8 (20-30A), Back Striking (pkg.10)
10	5066	Extended Tip, Contact Cutting, Ø 0.9 (30-40A), Back Striking (pkg.10)
11	5067	Retaining Cap, 6 holes
<b>11</b>	<b>5068</b>	<b>Retaining Cap, 6 holes, Maximum Life</b>
12	5069	Double pointed Spacer
N/S	5025	Wrench for Electrode
13	5070	Contact Tip, Ø 0.9 (30-40A), Back Striking (pkg.10)
13	5071	Contact Tip, Ø 1.0 (40-50A), Back Striking (pkg.10)
13	5072	Contact Tip, Ø 1.1 (50-60A), Back Striking (pkg.10)
14	5073	Shield Cup Body
15	5074	Shield Cap, Hand
16	5076	Extended Shielded Tip, Ø 0.9 (40A), Back Striking (pkg.10)
16	5077	Extended Shielded Tip, Ø 1.0 (50A), Back Striking (pkg.10)
16	5078	Extended Shielded Tip, Ø 1.1(60A), Back Striking (pkg.10)
17	5131	Shield Cup Body
18	5132	Extended Shielded 40-60A PT-60 (pkg.10)
N/S	5081	Circle Cutting Attachment

Note – the bold items are equipped on the torch

Recommended starting kit for the Torch PT-60:

Pos.	Item No	Description	pc
	5085-1	Starting Kit for PT-60	
		<b>Content:</b>	
3	5055	Electrode, Back Striking (pkg.10)	4
5	5057	Tip, Contact Cutting, Ø 0.65 (10-20A),	1

		Back Striking (pkg.10)	
5	5058	Tip, Contact Cutting, Ø 0.8 (20-30A), Back Striking (pkg.10)	1
6	5060	Tip, Contact Cutting, Ø 0.9 (30-40A), Back Striking (pkg.10)	2
7	5061	Flat Tip, Cutting, Ø 1.0 (40-50A), Back Striking (pkg.10)	2
8	5063	Extended Electrode, Back Striking (pkg.10)	1
10	5066	Extended Tip, Contact Cutting, Ø 0.9 (30-40A), Back Striking (pkg.10)	1
12	5069	Double pointed Spacer	1

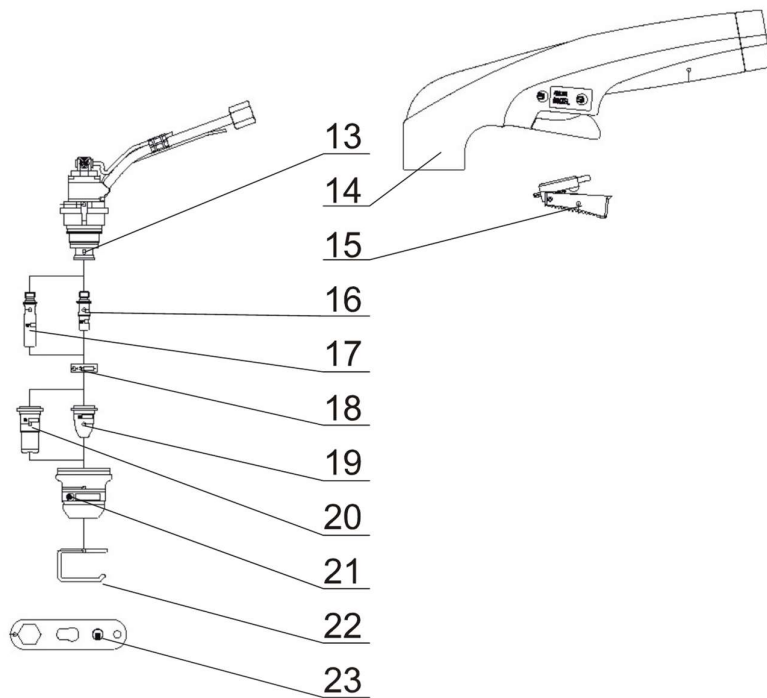

Fig. 4b Torch ABICUT 45

Pos.	Item No	Description
13	748.0020.1	Torch body ABI25/45
14	748.0053.1	Handle ABI25/45
15	185.0005	Switch ON/OFF
16	748.0032.10	Electrode standard ABI25/45
17	748.0048.10	Electrode Long ABI25/45
18	748.0033.2	Air diffuser ABI25/45
19	748.0034.10	Cutting Tip 0,65 Standard ABI25/45
19	748.0035.10	Cutting Tip 0,8 Standard ABI25/45

19	748.0061.10	Cutting Tip 1,0 Standard ABI25/45
20	748.0049.10	Cutting Tip 0,9 Long ABI25/45
<b>21</b>	<b>748.0052.2</b>	<b>Shield Cup ABI 45-35A</b>
21	748.0043.2	Shield Cup ABI45- 45A
22	748.0050.5	Standoff Guide ABI25/45
<b>23</b>	<b>748.0059.1</b>	<b>Multi key ABI25/45</b>
	<b>748.0057.1</b>	<b>Cable bundle ABI45</b>

Note – the bold items are equipped on the torch

Recommended starting kit for the Torch ABICUT 45 PEGAS:

Pos.	Item No	Description	pc
	748.START	Starting Kit for ABICUT 45 PEGAS	
		<b>Content:</b>	
16	748.0032.10	Electrode standard ABI25/45	2
17	748.0048.10	Electrode Long ABI25/45	1
19	748.0035.10	Cutting Tip 0,8 Standard ABI25/45	4
19	748.0061.10	Cutting Tip 1,0 Standard ABI25/45	1
20	748.0049.10	Cutting Tip 0,9 Long ABI25/45	2
21	748.0043.2	Shield Cup ABI45 45A	1
22	748.0050.5	Standoff Guide ABI25/45	1

## COMMENTS ON CONSUMABLES

### Shield cups – Retaining cups

#### PT-60

1. You can choose from two shield cups. Both have 6 holes for the compressed air.
2. For longer life particularly when cutting at 40 A we suggest to use nozzle 5068.

#### ABICUT45

1. You can choose from two shield cups. They differ in the number of holes for compressed air (4 respectively 6 holes). It is appropriate to use shield cup 748.0052.2 (35 A) for lower power, cut would be better.
2. For maximum performance it is necessary to use shield cup 748.0043.2 (45A) with six holes for air.

### Long electrode and a long cutting tip

1. The combination of Long electrode and Long cutting tip is aimed for cutting in angles or in spaces where standard electrode cannot reach.
2. It is possible to drag the Long cutting tip directly on the cutting material up to thickness of 5.8 mm without the guiding spring. The Lifetime of the cutting tip and the electrode is reduced by 30% - 50%.

### Standard electrode and standard cutting tips

#### PT- 60

1. For smaller cutting thickness (carbon steel) up to 4 mm it is better to use Cutting Tip 5057, Ø 0.65 (10-20A) in combination with electrode 5055.
2. For cutting thicknesses from 4 to 6mm use Cutting Tip 5058, Ø 0.8 (20-30A). For cutting thicknesses from 6 to 8 mm use Cutting Tip 5060, Ø 0.9 (30-40A). For cutting thicknesses over 8 mm use Cutting Tip 5061, Ø 1,0 (40-50A).

#### ABICUT45

1. It is possible to drag the standard cutting tip directly on the cutting material up to thickness of 10 mm without the guiding spring. The Lifetime of the cutting tip and the electrode is reduced by 30% - 50%.
2. It is better to use standard cutting tip 748.0034.10 0. (Cutting Tip 0,65 Standard ABI25/45) in combination with standard electrode 748.0032.10 for smaller cut thickness. Cut is narrower, better.

## 7. GETTING STARTED

Getting started must be consistent with technical data and conditions of use.

### TORCH CONNECTION SCHEMA

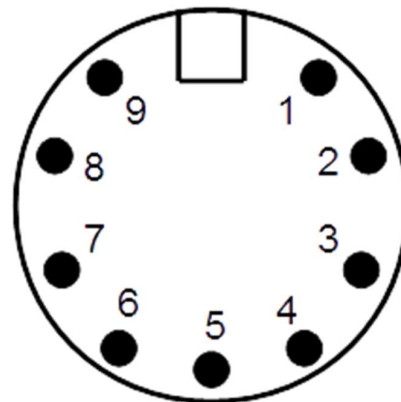

PIN NO.	TORCH
1	Trigger
2	Trigger
3	/
4	/
5	Pilot arc
6	Pilot arc
7	/
8	Safety





9	Safety
---	--------

## FIRST STEPS

 **NOTE**  This equipment must only be used by qualified personnel.

1. Before beginning work is necessary to connect the machine to the mains (1x110-230V, 50/60 Hz).
2. Check completeness of the mounted cutting torch.
3. Connect the compressed air quick connector to the connector on the rear wall of the machine.
4. Connect the mains plug to the mains.
5. After turning the power switch pos. **A12** the LED "ON" pos. **A4** must illuminate.
6. Connect the work lead cable to the material being cut.
7. Check the input pressure. The max. input pressure is 8,5 bar, the minimal input pressure is 4,4 bar.
8. Set potentiometer pos. **A3** to the cutting power you need.
9. Fit the torch with appropriate type of cutting tip electrode and shield cup according to the selected cutting current.
10. Switch the machine on by switch **A12**.
11. Press the torch trigger, the pilot arc will ignite.
12. Move the torch to the cutting material, the pilot arc will change to the cutting arc. If the pilot arc burns longer than 3 s, it automatically switches off.
13. Start with cutting. After the cut end release the torch trigger, the arc will switch off.
14. Switch off the machine, when is the post gas process done. It takes more than 1 minute.

## REQUIREMENTS FOR SOURCE OF COMPRESSED AIR

1. Delivered air pressure must be max. 8,5 bar and min. 4,4 bar.
2. Air consumption 170 l/min (for PT-60).
3. Compressed air for the plasma must be clean and dry.
4. Pressure dew point +3 °C.
5. Maximum oil content 0.1 mg/m<sup>3</sup>.
6. Maximal size of solid particles 15 microns.
7. The minimal size of an air tank is 50 l.
8. No additional oiling if the pressure air is permitted. That could damage the plasma machine and the cutting torch.

## OPTIONAL AIR FILTERS

To achieve high quality cutting and to avoid serious disturbances to the torch it is highly advised to include the air filter.

Pos.	Item No	Description
24	5302	Air filter AT 1000
25	5304	Set for filter AT 1000



Fig. 5 Air filter AT 1000

## 8. CUTTING

1. Press the torch trigger. The pilot arc will ignite. Then you have to immediately attach the torch to the cut material. At this point begins to burn the main arc between the torch and the material.
2. Move the torch with a constant speed. Cutting speeds vary according to torch output amperage, the type of material being cut, and operator skill.
3. Output current setting or cutting speeds may be reduced to allow slower cutting when following a line, or using a template or cutting guide while still producing cuts of excellent quality.
4. To achieve a good cutting quality make sure the distance between the tip and the material is about 2 mm. The Standoff Guide ABI25/45 pos. **22** located at the end of the plasma torch guarantees the distance. At a greater distance decreases cutting power and the arc may go off. With too small distance the torch parts will be worn off faster.

5. Plasma cutting may be done in all possible positions (vertically, horizontally, overhead, vertical ascending and descending), but as far as possible choose primarily horizontal cut. In other positions the operator is increasingly threatened by flying drops of molten material.
6. We recommend starting cutting at the edge of the material. If needed to start from the centre of the material, or to cut hole into the material, slightly tilt the torch head and gradually it straighten into a vertical position so the spraying material would not damage the cutting tip (see Figure 6). This workflow must always be followed, if the thickness of material is above 3 mm.
7. In case of cutting in the corner or around the corner (see Figure 7), use the long electrode and cutting tip (pos. **17** and **20**). The cutting power while using the Long cutting tip is decreased.

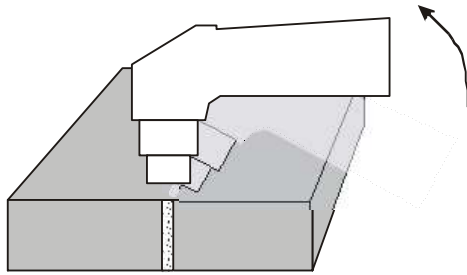

Fig. 6

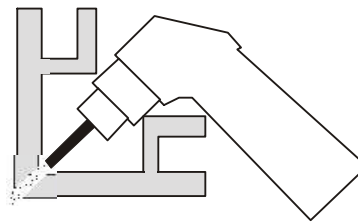

Fig. 7

### IMPORTANT RULES

1. The pilot arc burning time should be limited only to the time necessary. It lowers the wear of the cutting tips and electrodes.
2. Never turn off the main switch immediately after finishing cutting but always leave time to run cooling cycle to cool down the torch. Immediate turn-off only in case of emergency.
3. Ensure a good el. contact of the work lead clamps and cutting material.
4. Check and timely exchange cutting tips and the electrodes. Lifetime of these parts is only a few hours of cutting time and is highly dependent on compliance with the principles of good cutting.
5. Disconnect the machine from the mains before replacing the torch consumable parts.
6. Unplug the machine from the mains before any intervention inside the machine.
7. PEGAS 41 PLASMA PFC is adapted for use with torch ABICUT 45. This combination comply with EN 60974-7 Article 10.1.4. Using any other type and design of a torch must be approved by ALFA IN a.s.
8. Imperfect capture of condensate would cause its elimination in the area of the cutting tip and it would prevent ignition of the pilot arc.

## SOURCES OF POOR QUALITY CUTS

### Shallow penetration of the cut

1. The cutting speed is too high. Make sure the slope of the cutting arc does not exceed about  $15^\circ$  (see Figure 8).
2. High wear of the cutting tip or electrode (see Figure 9).
3. Too large thickness of material and not adequately chosen value of current and diameter of the cutting tip.
4. Bad contact between the work lead clamps and material.

### Cutting arc is unstable, goes off and "shoots"

1. Worn out cutting tip or electrode
2. High pressure
3. Impurities in the pressure air
4. not captured water condensate

### Conical cut

1. If there is a false cut (see Figure 10) turn off the machine, release the shield cup and rotate the cutting tip about  $1/4$  and again try to cut.
2. Damaged cutting tip and electrode.
3. The position of the torch is not perpendicular to the material.
4. Too large distance from the cutting tip to the material.

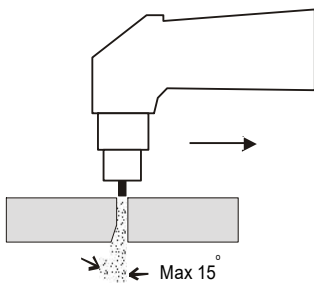

Fig. 8

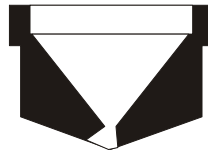

Fig. 9



Fig. 10

## 9. MAINTENANCE

1. A great care should be taken to the cutting torch. The molten material sprays while cutting. This sputter contaminates the interior space of the torch. The worn parts (consumables) of a plasma torch should be regularly maintained and timely exchanged. Regularly check the condition of diffuser channels (see diagram of the torch). If contaminated, you must clean it with a pressure air or to replace the diffuser. Poor state of the diffuser has a negative impact on the quality of cutting and causes very strong interference that may cause the collapse of the machine control electronics or influence the surrounding devices. If the cable bundle of the torch is worn out it must be replaced immediately - danger of electrical

shock.

2. Disconnect the PEGAS from the mains supply voltage before disassembling.
3. Special maintenance is not necessary for the control unit parts in the plasma cut machine. If these parts are damaged for any reason, replacement is recommended.



4. Do not blow air into the plasma cut during cleaning. Blowing air into the plasma cut can cause metal particles to interfere with sensitive electronic components and cause damage to the welder.
5. To clean the plasma cut, disconnect it from the mains supply voltage then open the enclosure and use a vacuum cleaner to remove any accumulated dirt and dust. The plasma cut should also be wiped clean. If necessary, solvents that are recommended for cleaning electrical apparatus may be used.
6. Troubleshooting and repairing of PEGAS equipment should only be carried out only by suitably qualified or competent person.
7. A 'competent person' must be a person who has acquired through training, qualification or experience, or a combination of them, the knowledge and skills enabling that person to safely carry out a risk assessment and repairs to the electrical equipment in question.
8. The person carrying out the servicing needs and repairs must know what to look at, what to look for and what to do.

## LUBRICATION OF THE ELECTRODE HOLDER WITH THE SILICONE LUBRICANT

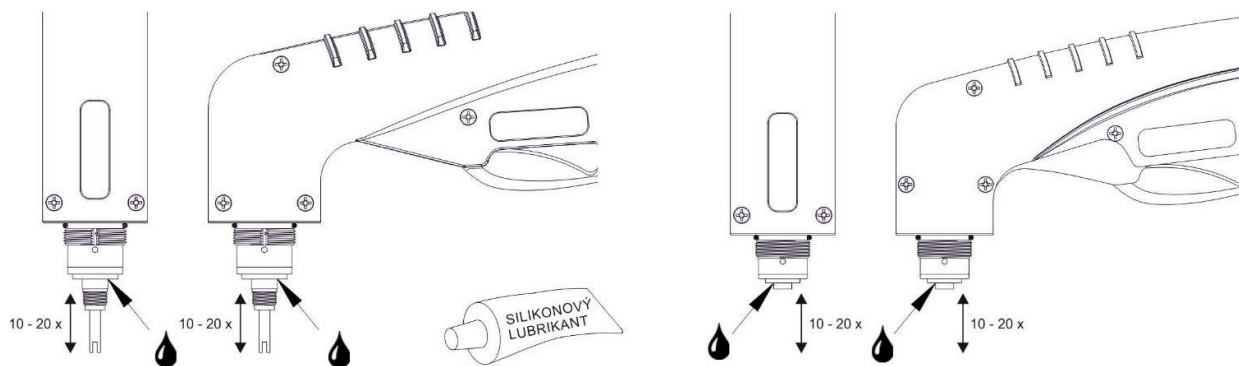

Fig. 11 Lubrication of the electrode holder

### Lubrication procedure:

1. Remove the retaining cap, cutting tip and swirl ring; keep the electrode in the electrode holder.
2. Lubricate the electrode holder with the silicone lubricant, as shown in the pictures above (ordering numbers of lubricants you can find in Accessories on request).

3. Then push the electrode up and down for 10-20 times for thorough lubrication.
4. Remove the excess silicone lubricant before putting the torch back together.

**Lubrication must be performed in the following cases:**

1. If is any difficulty in the movement of the electrode holder.
2. After the period of the prolonged inactivity.

Note: Thoroughly clean the electrode holder before lubricating it!

## **10. STATEMENT OF WARRANTY**

1. In accordance with the warranty periods stated below, ALFA IN guarantees the proposed product to be free from defects in material or workmanship when operated in accordance with the written instructions as defined in this operating manual.
2. ALFA IN products are manufactured for use by commercial and industrial users and trained personnel with experience in the use and maintenance of electrical welding and cutting equipment.
3. ALFA IN will repair or replace, at its discretion, any warranted parts or components that fail due to defects in material or workmanship within the warranty period. The warranty period begins on the date of sale to the end user.
4. If warranty is being sought, please contact your ALFA IN product supplier for the warranty repair procedure.
5. ALFA IN warranty will not apply to:
  - a. Equipment that has been modified by any other party other than ALFA IN's own service personnel or with prior written consent obtained from ALFA IN Service Department.
  - b. Equipment that has been used beyond the specifications established in the operating manual.
  - c. Installation not in accordance with the installation/operating manual.
  - d. Any product that has been subjected to abuse, misuse, negligence or accident.
  - e. Failure to clean and maintain (including lack of lubrication, maintenance and protection), the machine as set forth in the operating, installation or service manual.
6. Within this operating manual are details regarding the maintenance necessary to ensure trouble free operation.
7. Validity condition of warranty is, that the cutting machine must be used only with the torch, which is said in this manual.



8. Warranty repairs must be performed by either an ALFA IN Service Centre, an ALFA IN distributor or an Authorised Service Agent approved by the company ALFA IN.
9. As a warranty list serves proof of purchase (invoice) on which is the serial number of the machine, eventually a warranty list on the last page of this manual.

## 11. DISPOSAL



Only for EU countries. Do not dispose of electric tools together with household waste material.

In accordance with European Council Directive 2002/96/EC on electrical and electronic equipment waste and its implementation in accordance with national law, electric tools that have reached the end of their service life must be collected separately and returned to an environmentally compatible

recycling facility.

## 12. WARRANTY LIST

As a warranty list serves proof of purchase (invoice) on which is the serial number of the machine, eventually a warranty list below, which is filled in by an authorized dealer.

Serial number:	
Day, month (written in words) and year of sale:	
Stamp and dealer signature:	