

MIG/MAG WELDING MACHINES

AXE 250 *mobil* **MAN**

AXE 320 *mobil* **MAN**

INSTRUCTION MANUAL

CONTENT:

1. INTRODUCTION	3
2. SAFETY INSTRUCTIONS AND WARNINGS	4
3. CONDITIONS OF USE.....	7
4. TECHNICAL DATA.....	8
5. ACCESSORIES.....	9
6. DESCRIPTION OF THE APPLIANCE.....	9
7. GETTING STARTED	12
8. WELDING.....	15
9. ROUTINE MAINTENANCE & INSPECTION.....	16
10. STATEMENT OF WARRANTY	17
11. DISPOSAL.....	18
12. WARRANTY LIST	18

1. INTRODUCTION

Congratulations on your new ALFA IN product. We are proud to have you as our customer and will strive to provide you with the best service and reliability in the industry.

This Operating Manual has been designed to instruct you on the correct use and operation of your ALFA IN product. Your satisfaction with this product and its safe operation is our ultimate concern. Therefore please take the time to read the entire manual, especially the Safety Precautions. They will help you to avoid potential hazards that may exist when working with this product.

Read and understand this entire Manual and your employer's safety practices before installing, operating, or servicing the equipment. While the information contained in this Manual represents the Manufacturer's best judgement, the Manufacturer assumes no liability for its use.

AXE 250/320 mobil MAN are three phase sturdy welding machines for MIG/MAG welding.

The machines are designed to produce maximum power output combined with high reliability and efficiency.

We reserve the law of adjustments and changes in case of printing errors, change of technical paramaters, accessories etc. without previous notice. These changes may not be reflected in the manuals for use in paper or electronic form.



2. SAFETY INSTRUCTIONS AND WARNINGS

1. OPERATION AND MAINTENANCE OF WELDING EQUIPMENT CAN BE DANGEROUS AND HAZARDOUS TO YOUR HEALTH.
2. Arc welding produces intense electric and magnetic emissions that may interfere with the proper function of cardiac pacemakers, hearing aids, or other electronic health equipment. Persons who work near arc welding applications should consult their medical health professional and the manufacturer of the health equipment to determine whether a hazard exists.
3. Once the packing has been opened, make sure that the machine is not damaged. If in any doubt, call the service centre.
4. This equipment must only be used by qualified personnel.
5. During installation, any electric work must only be carried out by trained personnel.
6. The machine must be used in a dry place with good ventilation.
7. Make sure that no metal dust can be drawn in by the fan inside the machine, as this could cause damage to the electronic circuits.
8. It is prohibited to connect more than one generator in series or in parallel.
9. When installing the machine, follow the local regulations on safety.
10. The position of the machine must allow easy access by the operator to the controls and connectors.
11. When the welding machine is operating, all its covers and doors must be closed and well fixed.
12. Do not expose the welding machine to direct sunlight or to heavy rain. This equipment conforms to protection rating IP23S.
13. The operator must wear gloves, clothes, shoes, and a helmet or a welder's helmet, which protect and are fire-resistant in order to protect him against electric shock, flashes and sparks from cutting.
14. The operator must protect his eyes with safety visor or mask designed for welding, fitted with standard safety filters. He should also be aware that during arc welding ULTRAVIOLET RADIATION is emitted. Therefore it is vital that his face is also protected from radiation. Ultraviolet rays produce the same harmful effect as sun burning on unprotected skin.
15. The operator is obliged to warn anyone near the welding area of the risks that welding involves and to arrange to provide adequate protection equipment.
16. Keep all fumes and gases from the breathing area.
17. Keep your head out of the fume plume.
18. Use an air-supplied respirator if ventilation is not adequate to remove all fumes and gases.
19. The kinds of fumes and gases from the plasma arc depend on the kind of metal being used, coatings on the metal, and the different processes. You must be very careful when welding any metals which may contain one or more of the following:

Antimony	Chromium	Mercury
Nickel	Cobalt	Arsenic
Barium	Copper	Selenium
Beryllium	Lead	Silver
Cadmium	Manganese	Vanadium

20. Always read the Material Safety Data Sheets (MSDS) that should be supplied with the material you are using. These MSDSs will give you the information regarding the kind and amount of fumes and gases that may be dangerous to your health.
21. It is very important to arrange for sufficient ventilation, especially when welding in enclosed spaces. We suggest using suitable fume extractors to prevent the risk of intoxication by fumes or gas generated by the welding process.
22. Noise can cause permanent hearing loss. Welding arc processes can cause noise levels to exceed safe limits. You must protect your ears from loud noise to prevent permanent loss of hearing.
23. To protect your hearing from loud noise, wear protective ear plugs and/or ear muffs. Protect others in the workplace.
24. Noise levels should be measured to be sure the decibels (sound) do not exceed safe levels.
25. The operator must ensure all flammable materials are removed from the work area to avoid any risk of fire.
26. The operator must NEVER weld containers that have previously contained petrol, lubricants, gas or similar flammable materials, even if the container has been empty for a considerable time. THERE IS A VERY HIGH RISK OF EXPLOSION.
27. The operator must be aware of all the special regulations which he needs to conform to when cutting in enclosed spaces with a high risk of explosion.
28. To prevent electric shock, we strongly suggest the following rules:
29. Do not work in a damp or humid environment.
30. Do not use the machine if its cables are damaged in any way.
31. Make sure that the earthing system of the electric equipment is correctly connected and operational.
32. The operator must be insulated from the metal components connected to the return wire.
33. The earthing of the piece being worked could increase the risk of injury to the operator.
34. EN 60974-1 Standard: Open-circuit voltage. During the operation of the machine, the highest voltage, with which it is possible to come into contact, is the open-circuit voltage between the clamps.
35. The maximum open-circuit voltage of the plasma machines is established by national and international standards (EN 60974-1) depending on the type of current to be used, on its waveform and on the

hazards arising from the work place. These values are not applicable to the strike currents and those for stabilisation of the arc that could be above it.

36. The open-circuit voltage, for as many adjustments as possible, must never exceed the values relating to the various cases shown in the following table:

Case	Working conditions	Open-circuit voltage	
1	Places with increased risk of electric shock	DC current: 113V peak value	AC current: 68V peak value and 48V effective
2	Places without increased risk of electric shock	DC current: 113V peak value	AC current: 113V peak value and 80V effective
3	Torches held mechanically with increased protection for the operator	DC current: 141V peak value	AC current: 141V peak value and 100V effective
4	Plasma cutting	DC current: 500V peak value	

37. In case 1, the dc machines with rectifier must be built in such a way that, in case of a fault developing in the rectifier (for example open circuit, short circuit or lack of power), the permitted values cannot be exceeded. The

welding machines of this type can be marked with the symbol: 

38. Before opening the machine switch off the machine and disconnect it from the power socket.
39. Only personnel authorised by this company can carry out maintenance on the machine.

PROTECTIVE UTILITIES

1. Welding helmet with filter shade at least 10
2. Welding gloves
3. Welding apron and cloth
4. Welding boots

RISK OVERVIEW

1. Risk of electric shock.
2. Ultraviolet light and light radiation
3. Risk of inhaling gas fumes and dust particles
4. Burns
5. Noise

NOTE

1. It is forbidden to operate a machine with damaged insulation of the welding torch or supply cable.
2. Never operate the machine taken down or damaged covers.
3. It is forbidden to operate the machine in wet environments and outdoors in rain or snow.
4. Ensure proper grounding clamping pliers, which also reduces the risk of electric shock.
5. Use prescribed protective utilities, keep them dry.
6. Arc welding produces intense electric and magnetic emissions that may interfere with the proper function of cardiac pacemakers, hearing aids, or other electronic health equipment. Persons who work near plasma arc cutting applications should consult their medical health professional and the manufacturer of the health equipment to determine whether a hazard exists.
7. Never aim the torch against the eyes, body or other person.

3. CONDITIONS OF USE

1. This equipment must only be used by qualified personnel.
2. During installation, any electric work must only be carried out by trained personnel.
3. Device complies with IEC 61000-3-12.
4. Do not expose the plasma machine to direct sunlight or to rain or snow. This equipment conforms to protection rating IP23S.
5. Working ambient temperature between -10 and +40 °C.
6. Relative humidity below 90% at +20 °C.
7. Up to 3000 m altitude.
8. Place the machine the way that the cooling air can enter the vents without restriction to. It is necessary to ensure that no impurities, especially metal particles, are not drawn into the machine.
9. Welding machine in terms of interference suppression is intended primarily for industrial premises. In the case of use of other areas may be need for special measures (see EN 60974-10).
10. The machine must be protected against
 - a. Moisture and rain and snow
 - b. Mechanical damage
 - c. Draft and any ventilation of neighbouring machine
 - d. Excessive overloading - crossing technical parameters
 - e. Rough handling

ELECTROMAGNETIC COMPATIBILITY

The welding device is in terms of interference designed primarily for industrial areas. It meets the requirements of EN 60974-10 class A and it isn't designed for using in residential areas, where the electrical energy is supplied by public low-voltage power supply network. It can be here potential problems with ensuring of electromagnetic compatibility in this areas, due to interference caused by power lines as well as the radiated interference.

During operation, the device may be the source of interference.

 Caution 

We warn users, that they are responsible for possible interference from welding.

4. TECHNICAL DATA

Model		AXE 250 mobil MAN	AXE 320 mobil MAN
Method		MIG/MAG	MIG/MAG
Mains voltage	V/Hz	3 x 400/50-60	3 x 400/50-60
Mains protection	A	16 slow	16 slow
Max. input power I_1	A	16,4	23,4
Max. effective current I_{1eff}	A	12,9	12,9
Welding current range	A	20 - 250	40 - 315
Open-circuit voltage U_{20}	V	54,4	63,1
Welding current (DC=100%) I_2	A	210	210
Welding current (DC=60%) I_2	A	250	250
Welding current (DC=x%) I_2	A	60%=250	25%=315
Voltage setting		continuous	
Insulation class		F	
Protection		IP 23S	
Standards		EN 60974-1, EN 60974-10 cl. A	
Dimensions (w x l x h) generator	mm	240 x 640 x 438	240 x 650 x 438
Weight - compact/generator	kg	25,8	26,6

5. ACCESSORIES

DELIVERED WITH THE MACHINE

1. Feed roll 0,8 - 1,0mm

ACCESSORIES TO ORDER

1. Earthing cable 3 5 m with a clamp
2. Gas hose
3. Wire cleaner
4. CO2 Gas pre heating cable
5. Reduction valve
6. Gas cylinder
7. Torch consumables
8. Feed rolls 0,6-0,8 1,0-1,2 for carbon steels, aluminium, flux core wires
9. Torches with UP-DOWN remote control
10. Welding torches (see the table below)

Ordering No	
018.D975.1	Torch ABIMIG AT 305-C LW 3m
018.D976.1	Torch ABIMIG AT 305-C LW 4m
018.D977.1	Torch ABIMIG AT 305-C LW 5m

6. DESCRIPTION OF THE APPLIANCE

MAIN PARTS

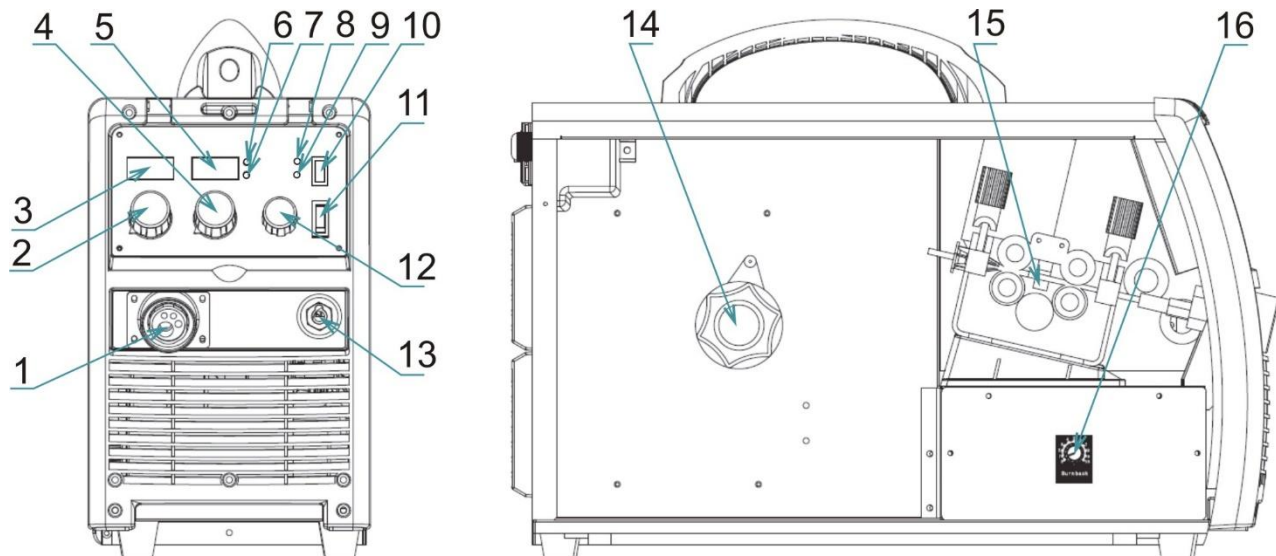

Fig. 1 - Main parts

1	EURO connector
2	Voltage potentiometer
3	Voltage Display

4	Wire Speed potentiometer
5	Current Display
6	LED indicator – if illuminated, the display shows the wire speed
7	LED indicator – if illuminated, the display shows the welding current
8	LED indicator - if illuminated, the machine is ON
9	LED indicator – if illuminated, the welder is over heated or the mains voltage is out of range
10	2 stroke/4 stroke switch
11	Wire feeding button
12	Choke potentiometer
13	Quick connector - (Earthing cable)
14	Spool holder
15	Wire feeder
16	Burn back potentiometer (0 – 10 ; 0 – 76 ms)

WIRE FEEDER

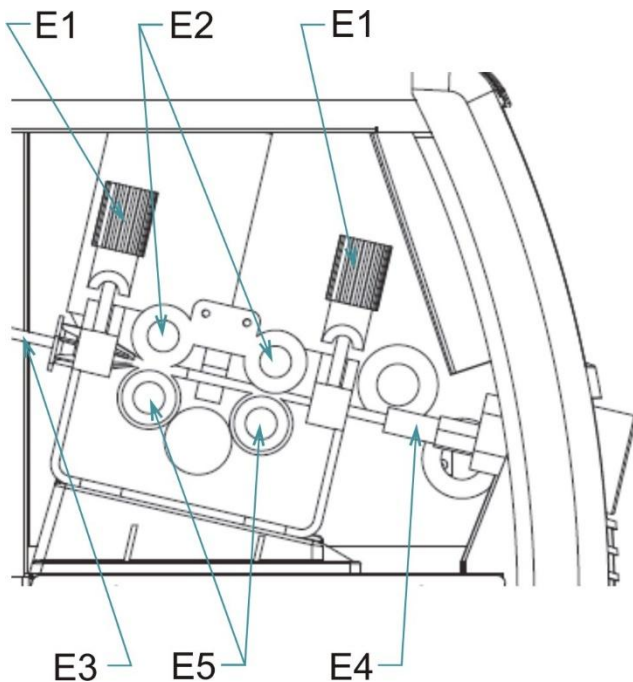
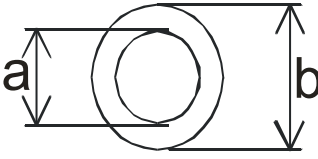
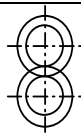
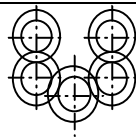
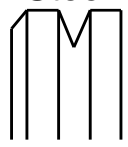
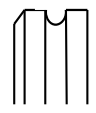
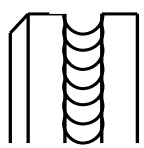

Fig. 2 - Wire feeder

		2 rolls	4 rolls
			
		a = 22 mm	a = 10 mm
		b = 30 mm	b = 30 mm
Grove type	Wire diameter	Item No	
Steel 	0,6-0,8	2187	5434
	0,8-1,0	2188	5435
	1,0-1,2	2189	5436
Aluminium 	0,8-1,0	2270	5437
	1,0-1,2	2269	5438
Flux core 	0,8-1,0	2318	5439
	1,0-1,2	2319	5440
	1,2-1,4	2320	5441

7. GETTING STARTED

Getting started must be consistent with technical data and conditions of use.

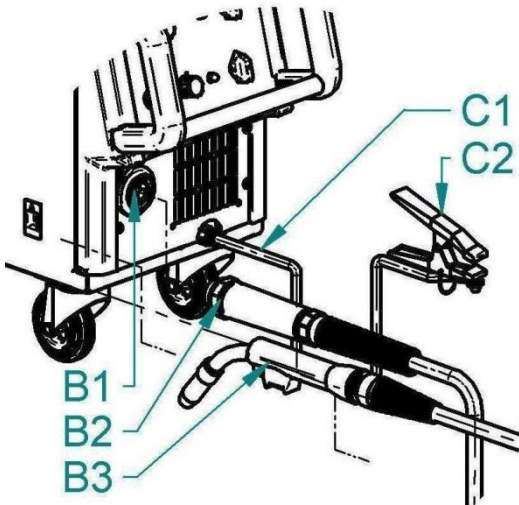
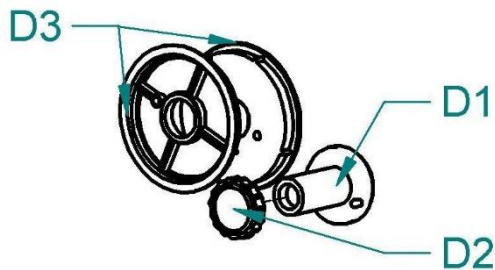

Fig 3 – Earthing cable and Welding Torch connecting (The picture is just for illustration, for the real position use Fig. 1)

C1	Quick connector - (Earthing cable) (Fig. 1, 13)
C2	Earthing clamp
B1	EURO connector (Fig. 1, 1)
B2	Torch Euro Connector Male
B3	Welding Torch

1. Connect the earthing clamp **C2** to the welding piece.
2. Connect the **B1** and **B2** torch connectors together. Screw them up properly by mean turning the **B2** clockwise.
3. Plug the mains plug to 3x400 V mains.
4. Switch the machine on by the ON/OFF switch at the rear panel of the welder.

INSERTING THE WIRE



D1	Spool Holder
D2	Nut Spool Holder
D3	Adapter

Fig. 4 – Spool holder

1. Open the side cover of the wire feeder space.
2. Put the wire spool on the wire spool holder **D1** using the adapter **D3** and fix it with the fixing nut **D2**.

3. Cut off the curved or damaged end of welding wire and lead it through the inlet liner **E3**, and the roll into the liner inside the EURO torch connector (about 5 cm). Make sure, that you use the suitable groove.
4. Put the pressure arm **E2** down in that way, that the teeth or the gear fit and fix it by setting the lever **E1** into vertical position.
5. Adjust the pressure nut that way that it provides constant movement of wire but it does not deform wire.

CHANGING THE WIRE FEEDER ROLL

1. Every wire feeding roll in ALFA IN machines can be used for two different diameters of welding wire – the rolls have two grooves.
2. When the machine is equipped with two roll wire feeder move the lever **E1** to the right (2 roll feeder)/ forward (4 roll feeder). The pressure arm shall pop up.
3. Unscrew the plastic fixing cup **E5** and take off the roll
4. In case there is suitable groove on the roll, turn it around and fix it back to the feeder.

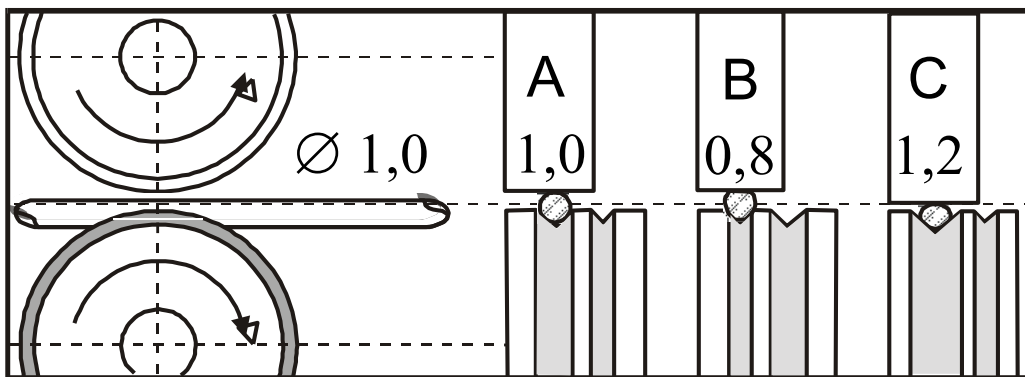

Fig. 5- The influence of the roll groove on the wire

A	Correct
B	Wrong
C	Wrong

ADJUSTING THE MACHINE FOR WELDING OF ALUMINIUM

1. For feeding the AL wire it is necessary to use roll with the "U" profile of the groove. To prevent problems with feeding use wires with diameter 1,0 or more mm of AlMg3 or AlMg5. The torch must be equipped with Teflon liner and special tip. As shielding atmosphere use Argon.

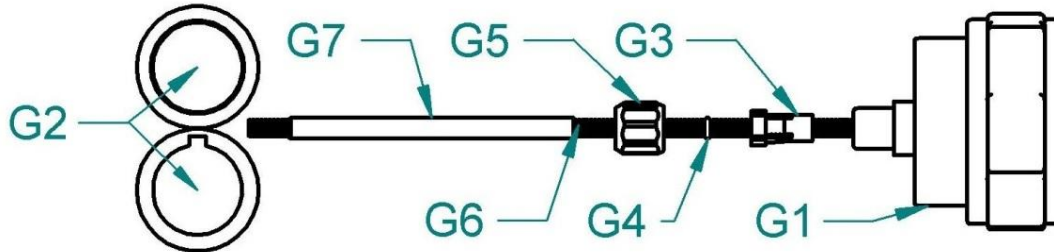

Fig 6 – Set for welding aluminium

G1	EURO connector
G2	Rolls
G3	Liner terminal for 4,0mm, 4,7mm outer diameter
G4	O – ring 3,5x1,5mm
G5	Nut
G6	Teflon Liner
G7	Sustain pipe for teflon and plastic liner

GAS FLOW SETTING

The electric arc and the weld must be perfectly shielded by gas. Too small amount of gas does not perform the protective atmosphere and on the other hand to big amount of the gas brings air into the electric arc.

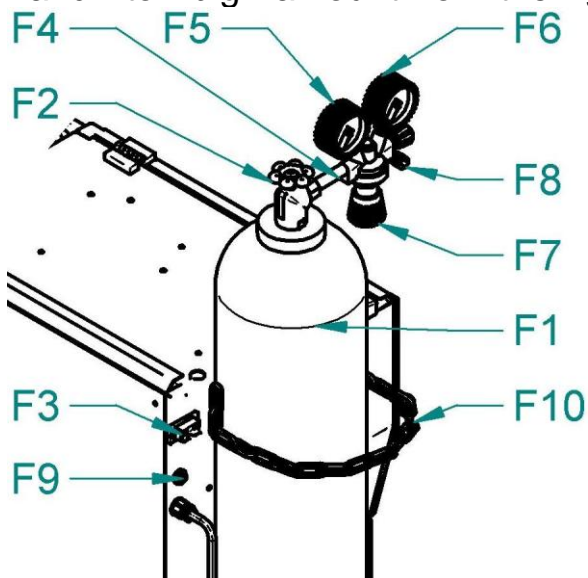

Fig. 7 – Gas fitting. The picture is just for illustration. The portable AXE 250/320 mobil MAN are not equipped to support the gas cylinders. The gas cylinders must be well fitted in another gadget in accordance with the appropriate safety rules.

F1	Gas Cylinder
F2	Cylinder Valve
F3	Gas heater connector
F4	Pressure Reducer
F5	High Pressure Manometer
F6	Low Pressure Manometer
F7	Adjusting Screw
F8	Gas outlet
F9	Solenoid Valve
F10	Chain

1. Place the gas cylinder on the platform and fix it properly by the fixing chain. We recommend using bolts and nuts to fix it more safely.
2. Connect the pressure reduction valve on the gas cylinder.
3. Connect the gas hose to gas outlet **F8** on the valve and the gas inlet **F9** on the machine.
4. Open the **F2** cylinder valve.
5. Press the button Gas test **11**.
6. Adjust the amount of gas on the reduction gas valve (it is not a part of the welding machine) by the **F7** adjusting screw.
7. Release the button **11** for digital.

8. WELDING

For orientating adjusting of the welding current and voltage you can use empirical relation $U_2 = 14 + 0,05 I_2$. From that you can specify desired voltage.

SETTING WELDING CURRENT AND VOLTAGE

When the wire had been installed and gas had been set it is possible to start welding.

The appliance must be plugged into the mains, the ON/OFF switch on "I". You will find the ON/OFF switch on the rear panel of the welder.

To select the voltage potentiometer **2**.

To select the current (that is linked to the wire speed) use the voltage potentiometer **3**

To modify the arc characteristic use the chope potentiometer **12**.

WELDING MODES

Machines works in four modes:

1. continuous two stroke (2T)

2. continuous four stroke (4T)

To select the mode switch the 2T/4T switch into the appropriate position.

TABLE OF WIRE CONSUMPTION DURING WELDING

Wire diameter [mm]	Range of wire feed speed [m/min]	Maximal wire feed speed [m/min]	Weight of 1 m wire [g]	Wire consumption per 1 minute of welding [g/min]	Wire consumption per 1 hour of welding [g/hour]
Steel wire					
0,6	2 - 5	5	2,3	11,5	690
0,8	3 - 6	6	4	24	1440
1,0	3 - 12	12	6	72	4320
1,2	4 -18	18	9	162	9720
Stainless steel wire					
0,6	2 - 5	5	2,3	11,5	690
0,8	3 - 6	6	4	24	1440
1,0	3 - 12	12	6	72	4320
1,2	4 -18	18	9	162	9720
Aluminum wire					
0,6	2 - 5	5	0,8	4	240
0,8	3 - 6	6	1,3	7,8	468
1,0	3 - 12	12	2	24	1440
1,2	4 -18	18	3	54	3240

TABLE OF GAS CONSUMPTION DURING WELDING

Wire diameter [mm]	Gas flow [l/min]	Gas consumption per 1 hour of welding [l/hour]
0,6	6	6 * 60 = 360
0,8	8	8 * 60 = 480
1,0	10	10 * 60 = 600
1,2	12	12 * 60 = 720
1,6	16	16 * 60 = 960
2,0	20	20 * 60 = 1200

9. ROUTINE MAINTENANCE & INSPECTION

1. The only routine maintenance required for the AXE range of machines is a thorough cleaning and inspection, with the frequency depending on the usage and the operating environment.

 **WARNING** 

2. Disconnect the AXE from the mains supply voltage before disassembling.
3. Special maintenance is not necessary for the control unit parts in the

Welder. If these parts are damaged for any reason, replacement is recommended.

 CAUTION 

4. Do not blow air into the welder during cleaning. Blowing air into the welder can cause metal particles to interfere with sensitive electronic components and cause damage to the welder.
5. To clean the welder, disconnect it from the mains supply voltage then open the enclosure and use a vacuum cleaner to remove any accumulated dirt and dust. The welder should also be wiped clean. If necessary, solvents that are recommended for cleaning electrical apparatus may be used.
6. Troubleshooting and repairing of AXE welding equipment should only be carried out only by suitably qualified or competent person.
7. A 'competent person' must be a person who has acquired through training, qualification or experience, or a combination of them, the knowledge and skills enabling that person to safely carry out a risk assessment and repairs to the electrical equipment in question.
8. The person carrying out the servicing needs and repairs must know what to look at, what to look for and what to do.

10. STATEMENT OF WARRANTY

1. In accordance with the warranty periods stated below, ALFA IN guarantees the proposed product to be free from defects in material or workmanship when operated in accordance with the written instructions as defined in this operating manual.
2. ALFA IN welding products are manufactured for use by commercial and industrial users and trained personnel with experience in the use and maintenance of electrical welding and cutting equipment.
3. ALFA IN will repair or replace, at its discretion, any warranted parts or components that fail due to defects in material or workmanship within the warranty period. The warranty period begins on the date of sale to the end user.
4. If warranty is being sought, please contact your ALFA IN product supplier for the warranty repair procedure.
5. ALFA IN warranty will not apply to:
6. Equipment that has been modified by any other party other than ALFA IN's own service personnel or with prior written consent obtained from ALFA IN Service Department.
7. Equipment that has been used beyond the specifications established in the operating manual.
8. Installation not in accordance with the installation/operating manual.
9. Any product that has been subjected to abuse, misuse, negligence or accident.
10. Failure to clean and maintain (including lack of lubrication, maintenance

and protection), the machine as set forth in the operating, installation or service manual.

11. Within this operating manual are details regarding the maintenance necessary to ensure trouble free operation.



12. Warranty repairs must be performed by either an ALFA IN Service Centre, an ALFA IN distributor or an Authorised Service Agent approved by the company ALFA IN.
13. As a warranty list serves proof of purchase (invoice) on which is the serial number of the machine, eventually a warranty list on the last page of this manual.

11. DISPOSAL



Only for EU countries. Do not dispose of electric tools together with household waste material.

In accordance with European Council Directive 2002/96/EC on electrical and electronic equipment waste and its implementation in accordance with national law, electric tools that have reached the end of their service life must be collected separately and returned to an environmentally compatible recycling facility.

12. WARRANTY LIST

As a warranty list serves proof of purchase (invoice) on which is the serial number of the machine, eventually a warranty list below, which is filled in by an authorized dealer.

Serial number:	
Day, month (written in words) and year of sale:	
Stamp and dealer signature:	