

WELDING MACHINES

**AXE 250 IN MIG SYN
AXE 320 IN MIG SYN**

INSTRUCTION MANUAL

CONTENT

1	INTRODUCTION	3
2	SAFETY PRECAUTIONS	4
3	OPERATING CONDITIONS.....	4
4	TECHNICAL DATA	6
5	EQUIPMENT.....	7
6	DESCRIPTION OF THE APPLIANCE.....	7
7	BASIC SETTINGS	13
8	MMA WELDING (COATED ELECTRODE- ELE)	20
9	ROUTINE MAINTENANCE & INSPECTION.....	20
10	STATEMENT OF WARRANTY.....	23
11	DISPOSAL.....	24
12	WARRANTY LIST.....	24

1 INTRODUCTION

Dear Consumers!

Company ALFA IN a.s. thanks you for buying our product and believe that you will be satisfied with our machine.

Welding machine AXE 250/320 IN MIG SYN is IGBT inverter. It is designed for welding method MIG (Metal Inert gas) and MAG (Metal Active Gas). This is welding in protective atmosphere. We are using inert (inert) and active gases during welding. These methods are very productive and particularly suitable for the connections of structural steels.

With welding machine AXE 250/320 IN MIG SYN it is possible to weld different types of connections (blunt, single-sided, double-sided, fillet, lap etc.) using wire diameter from 0,6 – 0,8 mm, or 1,0 – 1,2 mm of different metals and alloys (carbon and alloy steels, aluminum alloys etc.).

S The machine can be used for welding in areas with increased danger of electric shock. Machines comply with the relevant requirements for CE marking.

We reserve the law of adjustments and changes in case of printing errors, change of technical parameters, accessories etc. without previous notice. These changes may not be reflected in the manuals for use in paper or electronic form.



2 SAFETY PRECAUTIONS

PERSONAL PROTECTION

1. For safety reasons, it is necessary to use welding gloves during welding. These gloves will protect you before intervention of electric current (open circuit voltage). It protects you against thermal radiation and splashing drops of hot metal too. Wear sturdy isolated shoes. Do not wear open shoes, because drops of hot metal can cause burns.
2. Do not look into the welding arc without eye and face protection. Always use good quality welding helmet with intact protective filter.
3. The persons appearing in the vicinity of the welding must be informed of the danger and must be equipped with protective equipment.
4. During welding, especially in small spaces, it is necessary to ensure an adequate supply of fresh air, because during welding, harmful fumes arise.
5. In tanks of gas, oil, fuel, etc., (even empty ones) do not make welding, because there is a chance of explosion.
6. In areas with chance of explosion special provisions are applied.
7. Welding machines that are subjected to great exertion must comply with specific security requirements. These include the rail pressure of the vessel etc. These connections may only be carried out by competently trained welders with the necessary permissions.

SAFETY REGULATIONS

1. Before use, the operator is obliged to inform himself about the legislation in the country of use that deals with safety for welding, metal welding and arc welding.
2. The CO₂ bottle of mixed gases must be handled in accordance with the regulations for working with pressure vessels.
3. The welder must use protective equipment.
4. Before working on the electrical part, removing the cover or cleaning it is necessary to disconnect the device from the network.

3 OPERATING CONDITIONS

1. Putting the machine into operation can be performed only by trained personnel and only within the technical provisions. The manufacturer is not liable for damages resulting from improper use or handling. For maintenance and repair, use only original spare parts from ALFA IN.
2. Device complies with IEC 61000-3-12.
3. The welding machine is tested according to the degree of protection IP 23S, which provides protection against the intrusion of solid bodies with a diameter greater than 12 mm and protection against ingress of water, falling on the machine in a vertical direction or max degree of 60°.
4. Working ambient temperature between -10 and +40 °C.
5. Relative humidity below 90% at +20 °C.

6. Up to 3000 m altitude.
7. The machine must be positioned so that cooling air can enter and leave through cooling vents with no problem. It is necessary to ensure that there are no mechanical equipment, especially metal particles (e.g. during grinding) drawn into the machine.
8. Handling handle is intended for movement, it is not designed to lifting the machine.
9. In case of overheating of the machine welding is automatically stopped and this condition is signalized by pilot light.
10. All interventions in the el. equipment as well as repair (removal of the plug, fuse replacement) should be performed by an authorized person.
11. With competent mains voltage and input must match the plug.
12. Do not use the machine for other purposes, such as defrosting pipes, starter source, etc.
13. For the welding machine, it is necessary to perform a periodic inspection once every 6/12 months by an authorized employee – see paragraph Routine maintenance & inspection.
14. The welding machine is designed especially for industrial areas. In case of using it in other areas there may exist special measures (see EN 60974-10).
15. The stability of the machine is guaranteed up to 10 ° inclination under the following conditions:
 - a. The machine must be secured against rolling away
 - b. The gas bottle with a maximum height of 0.9 m may be placed and properly anchored on the platform
16. It is necessary to protect the machine against:
 - a. Moisture and rain
 - b. Mechanical damage
 - c. Draft and possibly ventilation of neighboring machines
 - d. Excessive overloading – exceeding tech. parameters
 - e. Rough treatment
 - f. Chemically aggressive environments

ELECTROMAGNETIC COMPATIBILITY

The welding device is in terms of interference designed primarily for industrial areas. It meets the requirements of EN 60974-10 class A and it isn't designed for using in residential areas, where the electrical energy is supplied by public low-voltage power supply network. It can be here potential problems with ensuring of electromagnetic compatibility in this areas, due to interference caused by power lines as well as the radiated interference. During operation, the device may be the source of interference.

 **Caution** 

We warn users, that they are responsible for possible interference from welding.

4 TECHNICAL DATA

Technical data		AXE 250		AXE 320	
Method		MIG/MAG	MMA	MIG/MAG	MMA
Mains voltage	V/Hz	3 x 400/50-60		3 x 400/50-60	
Mains protection	A	16 @		16 @	
Max. mains current I ₁	A	16,4	18,2	23,4	22,9
Max. effective current I _{1eff}	A	12,9	13,0	12,9	12,8
The range of welding. current	A	20-250	30-250	20-315	30-300
Open circuit voltage U ₂₀	V	54,4		63,1	
Welding current (DZ=100%) I ₂	A	210	190	210	190
Welding current (DZ=60%) I ₂	A	250	230	250	230
Welding current (DZ=x%) I ₂	A	60%=2 50	60%=2 50	25%=3 15	15%=3 00
Protection		IP 23S			
Standards		EN 60974-1, EN 60974-10 cl. A			
Dimensions (w x d x h)	mm	474 x 911 x 670			
Weight	kg	47,6			
Wire feed speed	m/min	0,5 - 17	---	0,5 - 17	---
Spool diameter	mm	300	---	300	---
Spool Weight	kg	18	---	18	---

S The machine marked with this symbol can be used for welding in areas with an increased risk of electric shock.

The machine structure is designed so that, in any case, even if the failure rectifier does not exceed the permitted peak value of the open circuit voltage according to EN 60974-1, i.e., 113 V direct current or 68 V alternating.

5 EQUIPMENT

CONTENT OF DELIVERY

1. Rolls for wire with diameter 0,8- 1,0 mm
2. Operating manual
3. Reduction for wire spool 5 kg and 15 kg
4. Earthing cable 3m with clamp
5. Hose for gas connection

ACCESSORIES ON REQUEST

1. Pressure reducer
2. Spare parts for the torch
3. Rolls 0,6-0,8; 1,0-1,2 with different groove designs
4. Torch ABIMIG 305 délka 3 m – 5 m
5. Torch MIG PARKER SG 240 délka 3 m – 5 m
6. Torch PARKER DIGIMIG 240 délka 3 m – 5 m
7. Wire cleaner
8. Electrode module
9. UP-DOWN module

NOTICE If you decide to use a different torch than the above, it is necessary to choose one, according to your current range and load time of the torch. ALFA IN a.s. is not liable for damage caused by overload welding torches.

6 DESCRIPTION OF THE APPLIANCE

MAIN PARTS

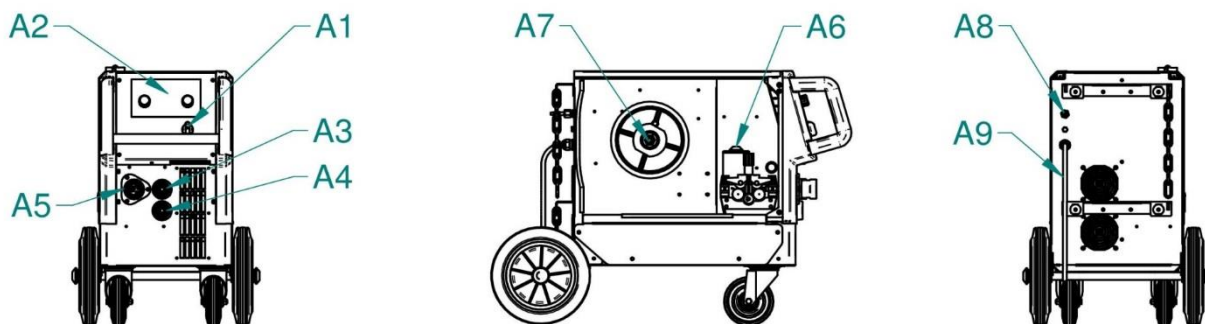

R051-1

Picture 1 – Main parts of the machine

A1	ON/OFF switch
A2	PCB control panel
A3	Quick connector (+)
A4	Quick connector (-)
A5	EURO connector

A6	Wire Feeder
A7	Spool Holder
A8	Solenoid Valve
A9	Mains Cable

WIRE FEEDER

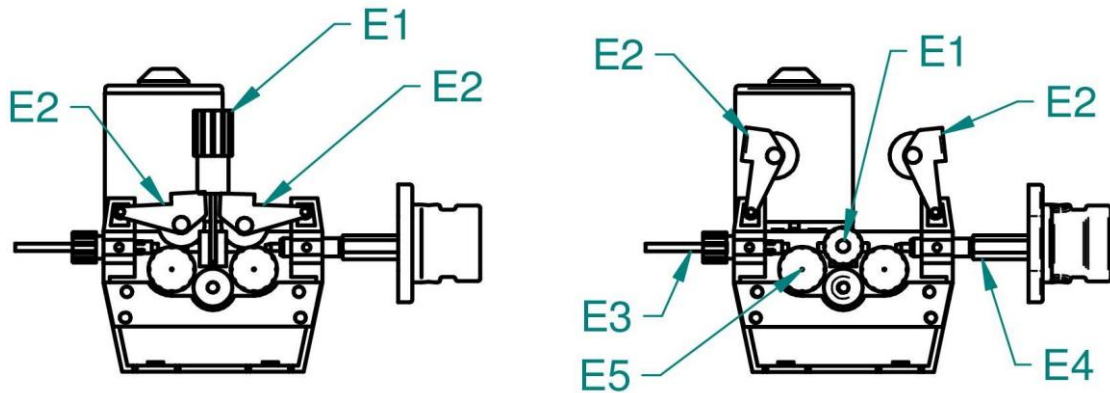

Picture 2 - Wire feeder 4 rolls

E1	Nut of pressure arm
E2	Pressure arm
E3	Inlet liner
E4	EURO connector
E5	Roll

CHOOSING THE FEEDING ROLL

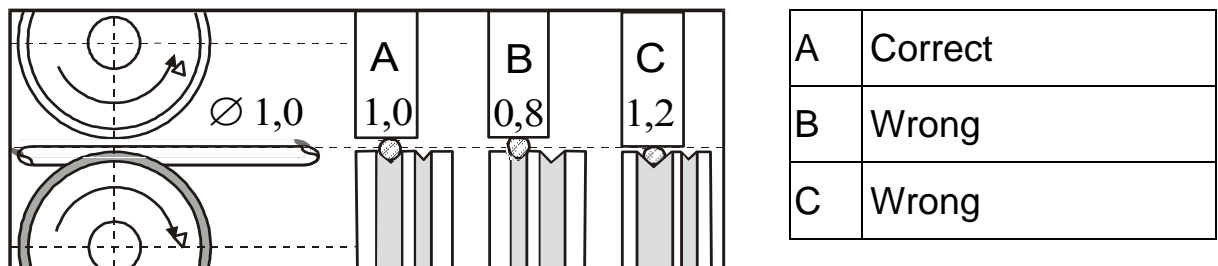

In all machines ALFA IN MIG / MAG rolls with two grooves are used. These grooves are intended for two different wire diameters (e.g. 0,8 and 1,0 mm).

Rolls for wire feed must comply with the diameter and material of the welding wire. Only this way a smooth wire feed can be achieved. Irregularities of the wire feed leads to a poor quality of welding and deformation of the wire.

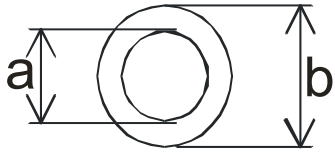
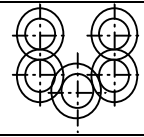

Picture 3 - The influence of the roll groove on the welding wire

OVERVIEW OF ROLLS FOR WIRE FEED

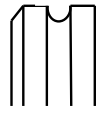
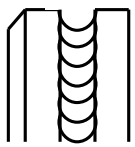
		4 rolls
		
		a = 22 mm
		b = 30 mm
Groove type	Wire diameter	Item No
Steel 	0,6-0,8	2187
	0,8-1,0	2188
	1,0-1,2	2189
Aluminum 	0,8-1,0	2270
	1,0-1,2	2269
Flux core 	0,8-1,0	2318
	1,0-1,2	2319
	1,2-1,4	2320

ADJUSTING THE MACHINE FOR ANOTHER WIRE DIAMETER

In all machines ALFA IN MIG / MAG are used rolls with two grooves. These grooves are intended for two different wire diameters (e.g. 0,8 a 1,0 mm). Groove can be replaced by removing the rolls and rotating them, or use a different roll grooves with required dimensions.

1. Open the nut **E1** to the right, pressure roll **E2** will be opened upward
2. Unscrew the plastic locking element **E5** and remove the roll
3. If there is a suitable groove on the roll, rotate the roll and place it back on the shaft and secure it by screwing the element **E5**.

ADJUSTING THE MACHINE FOR WELDING OF ALUMINIUM

For feeding the AL wire it is necessary to use roll with the “U” profile - see paragraph OVERVIEW ROLLS WIRE FEED. To prevent problems with feeding use wires with diameter. 1.0 mm of AlMg3 or AlMg. Wire of alloy Al99, 5 or AlSi5 are too soft and easily will cause problems with movement.

For the aluminum welding it is also necessary to provide the torch tefl. liner and special current nipple. We do not recommend you to use the torch longer than 3 m. Great attention must be paid to adjust the contact power of rolls – it must not be too high, otherwise there is a deformation of the wire.

As a protective atmosphere is necessary to use argon.

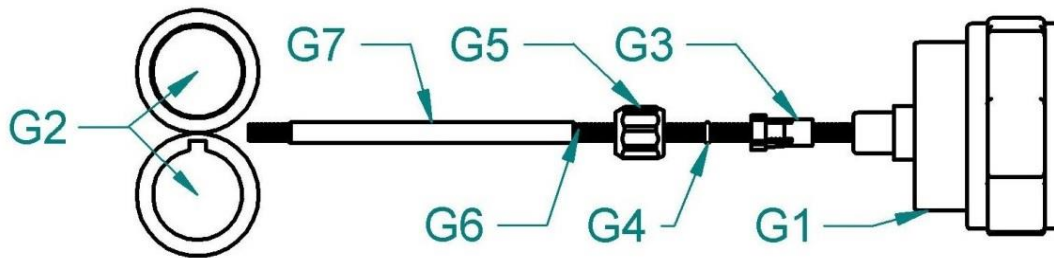

Picture 4 – Customization of the feed for the aluminium wire

G1	EURO connector
G2	Rolls
G3	Liner terminal for 4,0mm, 4,7mm outer diameter
G4	O-ring 3,5 x1, 5mm to prevent escape of gas
G5	Nut
G6	Liner tefl.
G7	Sustain pipe for teflon and plastic liner

INSERTING THE WIRE

1. Open the side cover of the wire feeder space.
2. Put the wire spool on the wire spool holder **D1** and fix it with the fixing nut **D2**. If a spool (size of 15 or 18 kg) is used, put on each side of the spool adapter **D3**. The hole in the back of the adapter must fit into the pin on the wire spool holder!
3. Cut off the curved or damaged end of welding wire and lead it through the inlet liner **E3**, and the roll into the liner inside the EURO torch connector (about 5 cm). Make sure, that you use the suitable groove.
4. Put the pressure arm **E2** down in that way, that the teeth or the gear fit and fix it by setting the lever **E1** into vertical position.
5. Adjust the pressure nut that way that it provides constant movement of wire but it does not deform wire. The adjusting screw is located under the plastic screw **E1**.
6. The spool brake is set by the manufacturer. If necessary, the brake can be adjusted by a screw **D1** so that while stopping the feed, spool will be stopped on time (it will avoid excessive release of wire). However, too tight brake needlessly strains the feeding mechanism and thus slippage may occur in the wire rolls.

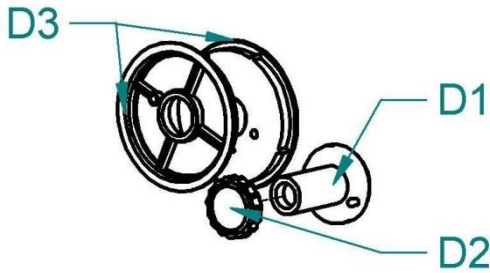

D1	Spool Holder
D2	Nut Spool Holder
D3	Adapter

Picture 5 - Spool holder

ADJUSTING PRESSURE FORCE OF FEED ROLLS

Important thing for reliable operation of the feeding mechanism is the size of pressure force of feed rolls.

The amount of force depends on the type of welding wire, for aluminum or tube wire, we choose a smaller pressure force

If the pressure force is too small, slippage may occur and thus irregular wire feeding speed.

If the pressure force is too high, it will lead to increased mechanical wear of bearings and it can damage the machine. Before putting into operation, clean the rolls from preservative oil.

INSERTING THE WIRE TO THE TORCH AND CONNECTION OF EARTH CABLE

1. Connect the earthing clamps to the welder or to the welding table.
 ⚠ Notice ⚠ When inserting the wire do not point with torch to the eyes!
2. Screw the central end of the torch **B2** to connector **B1** on the machine while the machine is turned off.
3. Remove the gas nozzle from the torch.
4. Unscrew the current nozzle.
5. Connect the machine to power supply.
6. Turn the main switch on the back panel to ON.
7. Press button (pic. 8) **V3**. The welding wire is fed into the torch. After coming off from the torch tube, screw the current nozzle and gas nozzle on.
8. Before welding, spray the area in a gas hose and current nozzle with a separation spray, to prevent damage.

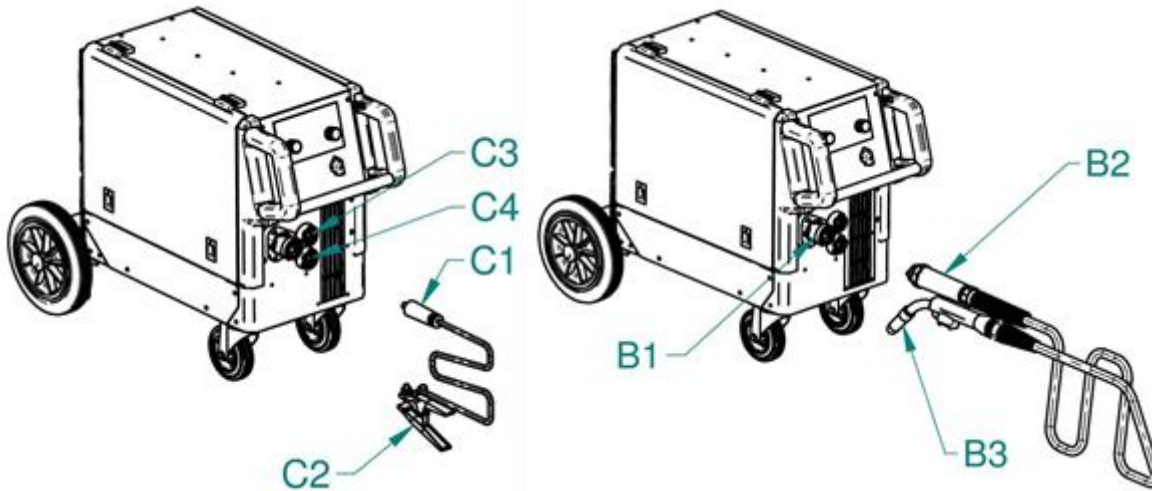

Picture 6 - Connection of torch and earth cable

B1	EURO connector, in pic. 1 position A1
B2	EURO connector male
B3	Torch
C1	Quick connector male
C2	Earthing clamps
C3	Quick connector (+)
C4	Quick connector (-)

ADJUSTMENT OF GAS FLOW

The electric arc and the weld must be perfectly shielded by gas. Too small amount of gas does not perform the protective atmosphere and on the other hand to big amount of the gas brings air into the electric arc.

Notice Gas bottle must be well secured against fall. This manual does not solve the safe securing of gas bottle. Information can be obtained from a supplier of industrial gases.

1. Fit the gas hose to the outlet on the back panel of the machine.
2. Press button (pic. 8) **V2** on the main panel. If you hold the button for less than 3 s, after releasing the button, the gas valve will turn off. If you hold the button for more than 3 s, it will turn off the gas valve after about 20 s, or after pressing any button.
3. Turn the adjusting screw **F7** at the bottom side pressure reducing valve, until the meter **F6** shows the required flow, then release the button. The optimum flow is 10-15l/min.
4. After long-term shutdown of the machine or replacement of the torch it is suitable to blow the pipes with protective gas before welding.

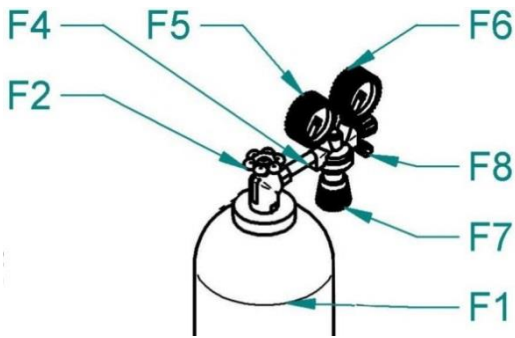

Picture 7 – Gas flow setting

F1	Gas bottle
F2	Cylinder Valve
F4	Pressure Reducer
F5	High Pressure Manometer
F6	Low Pressure Manometer
F7	Adjusting Screw
F8	Gas outlet

7 BASIC SETTINGS

CONTROL PANEL

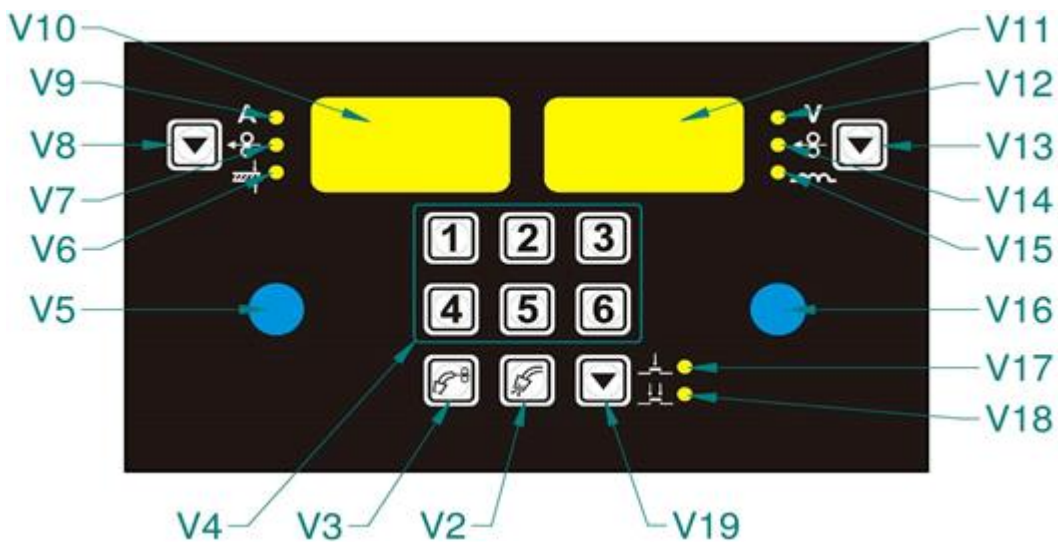

Picture 8 – Control panel

V2	Button gas test
V3	Button Wire Feeding
V4	Instant JOB buttons 1-6
V5	Current encoder
V6	Control light Material thickness (mm)
V7	Control light Wire speed (m/min)
V8	Button for selecting the parameters to be displayed
V9	Control light Current (A)
V10	Left display shows Welding current

	Speed of the wire Material thickness Sign of the secondary parameter
V11	Right display shows Welding voltage Welding current in the MMA mode Choke
V12	Control light of Voltage or Voltage Correction
V13	Button for selecting the parameters to be displayed
V14	Control light of Wire Speed Correction
V15	Control light of Choke or Choke Correction
V16	Encoder Voltage or Correction
V17	Control light two stroke – 2T
V18	Control light four stroke – 4T
V19	Button for selecting the parameters to be displayed

SETTING THE METHOD OF WELDING

1. Long pressing the button **V5** opens the menu.
 2. By turning the button **V5** choose the method ELE (covered electrode MMA); MAN (MIG/MAG manual) or SYN (MIG/MAG synergistic). Confirm your choice by pressing the button **V5**.



QUICK SETTING THE JOB - MEMORY

Works for three welding methods.

1. Long press (4s) one of the buttons **V4** (1,2,3,4,5,6) to save set parameters to memory.
2. Short press one of the buttons **V4** (1,2,3,4,5,6) to load parameters from memory.

WELDING MODE 2T – TWO STROKE



Works for both welding methods MIG/MAG.

Press the button **V19** to switch between the modes **2T**  / **4T** . The two stroke mode is signaled by LED **V17**.

1. Tact – press and hold the button	the machine will start welding
2. Tact – release the torch button	the machine will stop

WELDING MODE 4T – FOUR STROKE

Works for both welding methods MIG/MAG.

Press the button **V19** to switch between the modes **2T**  / **4T** . The two stroke mode is signaled by LED **V18**.

1. Tact – press and hold the button	the machine will start welding
2. Tact – release the torch button	the machine will continue
3. Tact - press the torch button	the machine will continue
4. Tact - release the torch button	the machine will stop

SECONDARY PARAMETERS MENU

From start the welding machine is set to factory settings (default). For most of the work it is not appropriate to change the secondary parameters. Secondary parameters for manual and synergistic methods are identical.

1. Simultaneously pressing **V19** and **V5** encoder enters the menu for secondary parameters.
2. A5 encoder selects a parameter (ISP, PRG, PoG, brn), **V19** encoder sets the desired value.
3. Press the encoder **V5** to confirm the change.
4. Press any button to exit the menu without saving changes.

Symbol	Meaning	Range (Default)
ISP (Initial speed)	Approaching speed	10 - 100 % (30 %).
PrG (Pre gas time)	Pre gas	0 - 20 s (0,1 sec).
PoG (Post gas time)	Post gas	0 - 20 s (0,5 sec).
brn (Burn back)	Burn back	0 - 75 ms (35 ms)
CAL (Calibration menu)	Calibration menu	x.xx (version sw PCB engine)

The last menu item is **CAL** – it is used to enter the calibration menu, which is intended only for authorized service.

REMOTE CONTROL

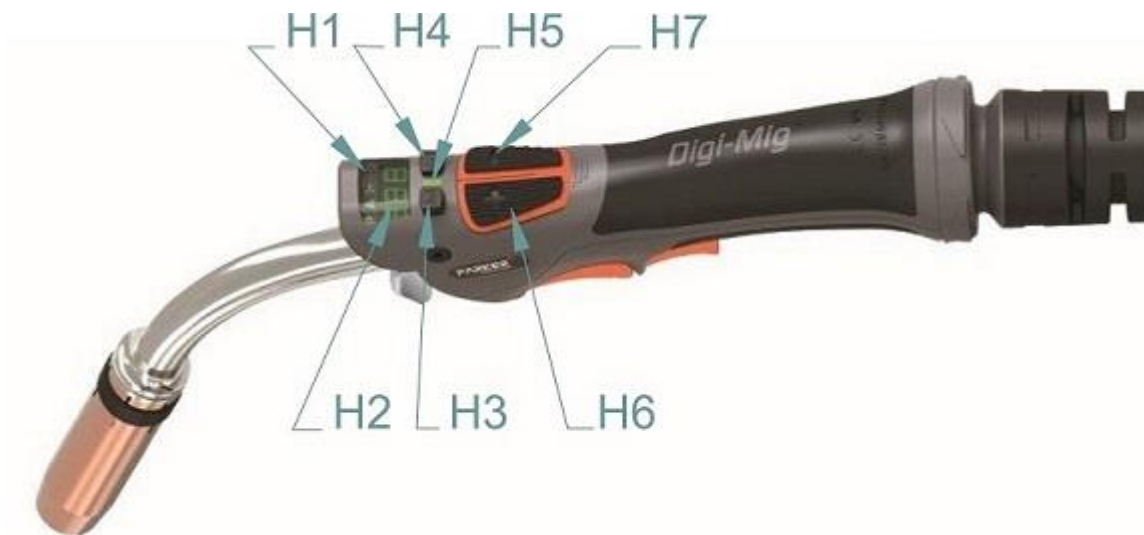



Picture 9 – Remote control from the torch

H1	Display of remote control
H2	Display
H3	Torch button M for choosing the function MAN: Wire speed, Voltage/Choke, JOB (See How to switch on the remote control of JOBS on below) SYN: Power, Correction/Choke, JOB
H4	Torch button LOCK lock/unlock the buttons UP/DOWN and M The UP/DOWN and M buttons get automatically locked when the torch trigger is pressed.
H5	When the LED is on it indicates UP/DOWN and M button are functioning.
H6	Torch button UP
H7	Torch button DOWN

HOW TO SWITCH ON THE REMOTE CONTROL OF JOBS

1. Press buttons **V13** and **V19** at the same time for more than 3 s. The displays **V10** and **V11** will show JOB ON. (To switch off this function, press **shortly V13** and **V19** at the same time.
2. By means of the button **H3** set the function JOB change.
3. By means of buttons **H6** (UP) and **H7** (DOWN) switch among the saved JOBS.

Symbols on the torch display H1	
Symbol	Description
P	A synergic program is running on the welding machine
A	Amperage setting (SYN)
	Wire speed setting
No symbol	Material thickness setting (SYN) Voltage setting (MAN)
	Correction (SYN)
Symbols on the torch display H2	
J.xx	JOBs (xx – JOB No)
I.xx	Choke level (SYN/MAN). (Only with firmware 2015 and newer)
ELE	Machine is in MMA (Electrode) mode

RESET

1. Pressing **V8** + **V19** at the same time more than 3 s makes RESET – default parameters will be restored.
2. It will delete saved JOBS!

MIG/MAG WELDING SYNERGY

1. Choose SYN method (see SETTING THE METHOD OF WELDING)
2. Left display **V10** shows SYN, right display **V11** shows the number of synergistic curve.
3. Selects synergic curve (program number) using encoder **V16** according to the table, which is located inside. To confirm the program number press the encoder **V5**.

AXE 250-320 IN	Ø 0.8 mm	Ø 1 mm	Ø 1.2 mm
Ar 82% CO ₂ 18% SG/Fe	0	1	2
CO ₂ SG/Fe	3	4	5
Ar 97,5% CO ₂ 2,5% Cr/Ni 308	6	7	8
Ar 97,5% CO ₂ 2,5% Cr/Ni 316	9	10	11

Picture 10 – Table of synergic curves

4. Use **V8** button to select the values you want to set the machine with, the corresponding light will illuminate.
5. Machine output (current, wire feed speed, material thickness) is set by the encoder **V5**.
6. If necessary, power and its characteristics can be fine-tuned by encoder **V16**.
7. The value of the voltage or the choke correction are shown on the display **V11** only during the configuration.
8. From the factory, the machine is set to use voltage correction. (to change the meaning of the correction from Voltage to Wire speed, press and hold the button **V13**). (When you change the welding power by turning the encoder **V5** it will reset the correction, in other words the machine uses parameters from the factory stored synergic curves. The machine supports the possibility of maintaining a user-defined correction when changing the welding power. Switching to such arrangements must be made by the manufacturer or an authorized service center.)
9. Button **V13** switches between correction of voltage and correction of the choke. Confirm the change with encoder **V16**.

MIG/MAG WELDING MANUAL

1. Choose MAN method (see SETTING THE METHOD OF WELDING)
2. The left display **V10** shows MAN.
3. The left display **V10** shows the wire feed speed, the right display **V11** shows voltage or choke.
4. Wire feed speed is set by the encoder **V5**.
5. Voltage or choke is adjusted via the encoder **V16**.
6. Voltage or choke can be displayed and set by long-pressing **V13**.
7. During welding, the display **V10** shows measured values of welding current and the display **V11** shows measured values of voltage.
8. After welding, on the displays will remain measured values (**HOLD**) for 6 sec.

WELDING VOLTAGE

It is set using voltage potentiometer pic. 8, **V16**.

WELDING CURRENT – GENERAL INFORMATION

Size of the welding current depends on the wire feed speed and voltage. Characteristic of the curve ("hardness / softness") can be controlled by correction of the choke.

Approximate setting for the MIG / MAG welding current and voltage corresponds the empirical relationship $U_2 = 14 + 0.05 I_2$. According to this relationship, we can determine the required voltage. When setting the voltage, we expect the

decline in voltage during load. The voltage drop is approximately 4.5-5.0 V at 100 A.

Set the welding current by setting the welding voltage first and then configure the wire feed speed to the point, where the burning of the arc is ideal.

Please note that the actual settings for ideal arc may vary slightly depending on the position of the weld material and voltage fluctuations.

To achieve a good quality of the welds and the optimum setting of the welding current it is necessary to ensure that the distance of the power nozzle from the material was about 10 times the diameter of the welding wire (pic. 8)

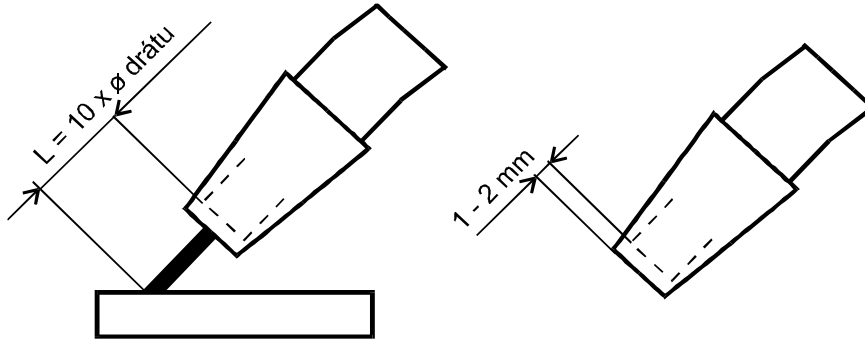

Picture 11 – Distance from nozzle to material

TABLE OF WIRE CONSUMPTION DURING WELDING

Wire diameter [mm]	Range of wire feed speed [m/min]	Maximal wire feed speed [m/min]	Weight of 1 m wire [g]	Wire consumption per 1 minute of welding [g/min]	Wire consumption per 1 hour of welding [g/hour]
Steel wire					
0,6	2 - 5	5	2,3	11,5	690
0,8	3 - 6	6	4	24	1440
1,0	3 - 12	12	6	72	4320
1,2	4 - 18	18	9	162	9720
Stainless steel wire					
0,6	2 - 5	5	2,3	11,5	690
0,8	3 - 6	6	4	24	1440
1,0	3 - 12	12	6	72	4320
1,2	4 - 18	18	9	162	9720
Aluminum wire					
0,6	2 - 5	5	0,8	4	240
0,8	3 - 6	6	1,3	7,8	468
1,0	3 - 12	12	2	24	1440
1,2	4 - 18	18	3	54	3240

TABLE OF GAS CONSUMPTION DURING WELDING

Wire diameter [mm]	Gas flow [l/min]	Gas consumption per 1 hour of welding [l/hour]
0,6	6	6 * 60 = 360
0,8	8	8 * 60 = 480
1,0	10	10 * 60 = 600
1,2	12	12 * 60 = 720
1,6	16	16 * 60 = 960
2,0	20	20 * 60 = 1200

8 MMA WELDING (COATED ELECTRODE- ELE)

1. Choose ELE method (see 7.2 SETTING THE METHOD OF WELDING)
2. The left display **V10** shows the value of welding current, the right display **V11** shows ELE.
3. The welding current is set by the encoder **V5**.
4. During welding, the display shows measured values of welding current.
5. After welding, on the display will remain measured value (HOLD) for 6 sec.
6. If the MIG/MAG remote torch stays connected, on its display will be shown ELE. The remote function will not work. Careful, the welding voltage will be on the torch.

TABLE OF ELECTRODE CONSUMPTION DURING WELDING

Electrode diameter [mm]	Range of welding current [A]	Total electrode length [mm]	Weight of boiled electrode without slag [g]	Boiled electrode time [s]	Weight of boiled electrode without slag per 1 second [g/s]
1,6	30 - 55	300	4	35	0,11
2,5	70 - 110	350	11	49	0,22
3,2	90 - 140	350	19	60	0,32
4,0	120 - 190	450	39	88	0,44

9 ROUTINE MAINTENANCE & INSPECTION

1. The only routine maintenance required for the aXe range of machines is a thorough cleaning and inspection, with the frequency depending on the usage and the operating environment.

 **WARNING** 

2. Disconnect the aXe from the mains supply voltage before disassembling.
3. Special maintenance is not necessary for the control unit parts in the Welder. If these parts are damaged for any reason, replacement is recommended.

CAUTION

4. Do not blow air into the welder during cleaning. Blowing air into the welder can cause metal particles to interfere with sensitive electronic components and cause damage to the welder.
5. To clean the welder, disconnect it from the mains supply voltage then open the enclosure and use a vacuum cleaner to remove any accumulated dirt and dust. The welder should also be wiped clean. If necessary, solvents that are recommended for cleaning electrical apparatus may be used.
6. Troubleshooting and repairing of the aXe welding equipment should only be carried out only by suitably qualified or competent person.
7. A 'competent person' must be a person who has acquired through training, qualification or experience, or a combination of them, the knowledge and skills enabling that person to safely carry out a risk assessment and repairs to the electrical equipment in question.
8. The person carrying out the servicing needs and repairs must know what to look at, what to look for and what to do.

OPERATIONAL SAFETY INSPECTION OF THE MACHINE ACCORDING TO EN 60 974-4

Prescribed operations of tests, procedures, and required documentation are listed in EN 60974-4. **SERVIS**

ERROR MESSAGES

The left display **V10** shows Err, the right display **V11** shows number of the error.

Err 1	Overheating of the machine. DO NOT POWER OFF THE MACHINE!
-------	---

TROUBLE SHOOTING

Symptom	Reason	Solution
The torch is too hot	Nozzle is not fixed.	Tighten the nozzle
Button on the torch does not respond	Connectivity of EURO connector is loose	Tighten EURO connector
	Damaged wiring in the torch	Check and replace if necessary.
Irregular wire feed or wire is caked to the nozzle.	The wire on the spool is too tightly wound.	Check and replace the spool if necessary.
	The ball is fused to the nozzle.	Cut out the ball and piece of the wire at the beginning.
Irregular or no wire feed.	Poor pressure in the wire feed rolls	Adjust the pressure according to this instruction manual.

	The torch is damaged.	Check and replace if necessary.
	The groove on the feed roll does not correspond to the welding wire diameter.	Put the correct roll.
	Bad quality of the wire.	Check and replace if necessary.
	The liner in the torch is unclean or damaged.	Check and replace if necessary
	Spool brake is badly configured.	Adjust it according to this instruction manual.
Arc or short circuit between the hose and the nozzle	Glued spatter inside the gas nozzle.	Remove the spatter.
Unstable arc	Incorrect diameter of the nozzle or too worn out or damaged nozzle.	Change the nozzle.
Inadequate supply of a protective gas, pores in the weld	Poorly set the amount of supplied gas.	Set the correct amount as described in this instruction manual.
	Reducing valve on the bottle is dirty	Check and replace if necessary.
	The torch or gas hoses are dirty	Check and replace if necessary.
	Protective gas is blown away by draft.	Stop the draft
Bad welding power	Missing phase.	Try to connect the machine to a different outlet. Check the power supply cable and circuit breaker.
	Poor grounding.	Ensure the best connection between the work piece and the earthing cable / clamps of the machine.
	The grounding cable is poorly attached to the connector on the machine.	Tighten the earthing cable in the connector on the machine.
	Torch damaged	Check and replace if necessary.

During feeding welding wire is rubbed.	The groove on the feed roll does not correspond to the welding wire diameter.	Put the correct roll.
	Wrong pressure in the upper wire feed roll	Adjust the pressure according to this instruction manual.

10 STATEMENT OF WARRANTY

1. In accordance with the warranty periods stated below, ALFA IN guarantees the proposed product to be free from defects in material or workmanship when operated in accordance with the written instructions as defined in this operating manual.
2. ALFA IN welding products are manufactured for use by commercial and industrial users and trained personnel with experience in the use and maintenance of electrical welding and cutting equipment.
3. ALFA IN will repair or replace, at its discretion, any warranted parts or components that fail due to defects in material or workmanship within the warranty period. The warranty period begins on the date of sale to the end user.
4. If warranty is being sought, please contact your ALFA IN product supplier for the warranty repair procedure.
5. ALFA IN warranty will not apply to:
 1. Equipment that has been modified by any other party other than ALFA IN's own service personnel or with prior written consent obtained from ALFA IN Service Department.
 2. Equipment that has been used beyond the specifications established in the operating manual.
 3. Installation not in accordance with the installation/operating manual.
 4. Any product that has been subjected to abuse, misuse, negligence or accident.
 5. Failure to clean and maintain (including lack of lubrication, maintenance and protection), the machine as set forth in the operating, installation or service manual.
6. Within this operating manual are details regarding the maintenance necessary to ensure trouble free operation.



NOTE

Warranty repairs must be performed by either an ALFA IN Service Centre, an ALFA IN distributor or an Authorized Service Agent approved by the company ALFA IN.

7. As a warranty list serves proof of purchase (invoice) on which is the serial number of the machine, eventually a warranty list on the last page of this manual.

11 DISPOSAL



Only for EU countries. Do not dispose of electric tools together with household waste material.

■ In accordance with European Council Directive 2002/96/EC on electrical and electronic equipment waste and its implementation in accordance with national law, electric tools that have reached the end of their service life must be collected separately and returned to an environmentally compatible recycling facility.

12 WARRANTY LIST

As a warranty list serves proof of purchase (invoice) on which is the serial number of the machine, eventually a warranty list below, which is filled in by an authorized dealer.

Serial number:	
Day, month (written in words) and year of sale:	
Stamp and dealer signature:	